

6.70 MULTI
type 500 / 1500 / 3000

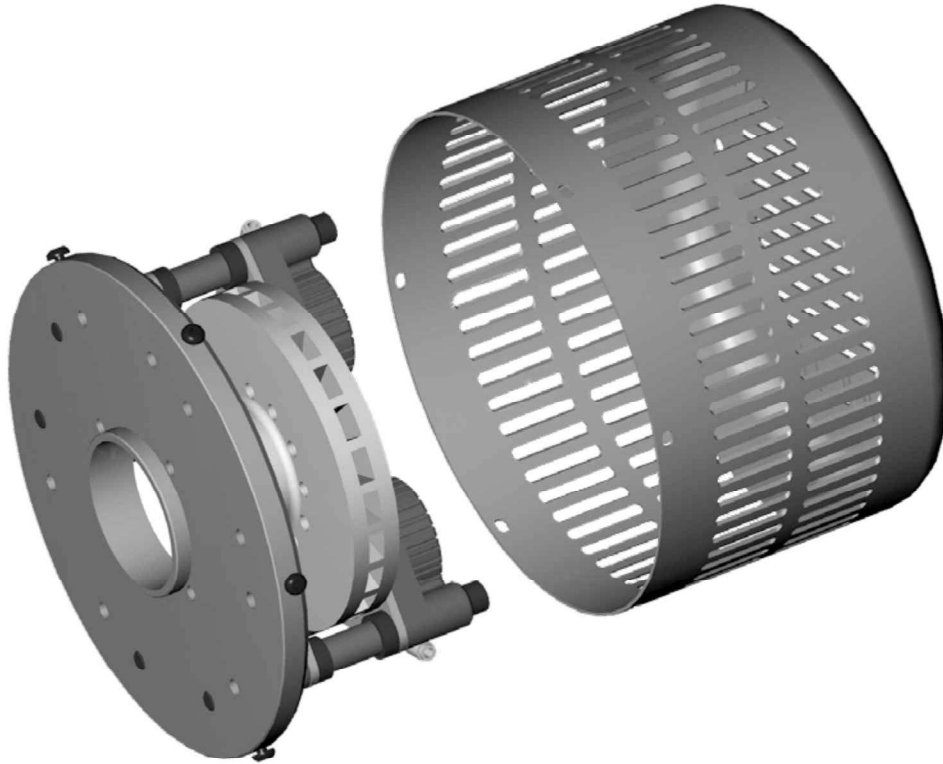

Multi pneum. disc-brake
 in variable modular-design construction

	MULTI		
	500	1500	3000
type 22-30 - 50-80			
performance kW (h.p.)	0.5 (0.671)	1.5 (2.012)	3.0 (4.023)
brake torque Nm (ft/lb) per calliper	50 (36.9)	80 (59)	120 (88.5)
max. callipers	6	8	10
brake torque with max. no. of callipers Nm (ft/lb)	300 (221.3)	640 (472)	1200 (885.1)

All data is on a basis of 5 bar (72.5 psi) pressure.

Safety Chuck with MULTI

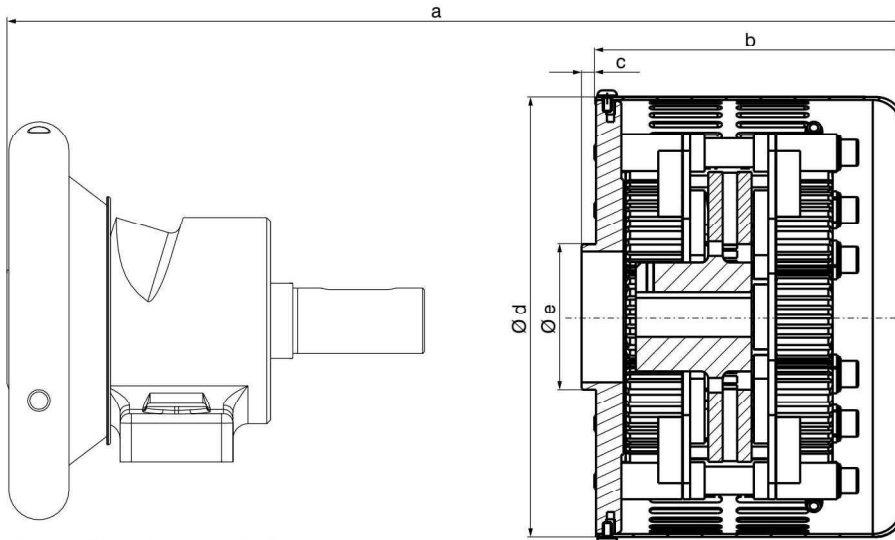

picture of chuck just symbolic

Multi 500

	a	b	c	d	e -0.1 / -0.2
Safety Chuck 22-30 + Multi	323	200	2	304	62
Safety Chuck 30-40 + Multi	340	200	5	304	80
Safety Chuck 40-50 + Multi	391	200	7.5	304	100
Safety Chuck 50-80 + Multi	460	200	7.5	304	140

Multi 1500

	a	b	c	d	e -0.1 / -0.2
Safety Chuck 22-30 + Multi	323	200	2	404	62
Safety Chuck 30-40 + Multi	340	200	5	404	80
Safety Chuck 40-50 + Multi	391	200	7.5	404	100
Safety Chuck 50-80 + Multi	460	200	7.5	404	140

Multi 3000

	a	b	c	d	e -0.1 / -0.2
Safety Chuck 22-30 + Multi	373	250	2	504	62
Safety Chuck 30-40 + Multi	390	250	5	504	80
Safety Chuck 40-50 + Multi	440	250	7.5	504	100
Safety Chuck 50-80 + Multi	510	250	7.5	504	140

Dimension schedule for Boschert-Chuck see chapter 2.20 - 2.40

Overall dimension MULTI with Sliding-, A- and P-Chuck

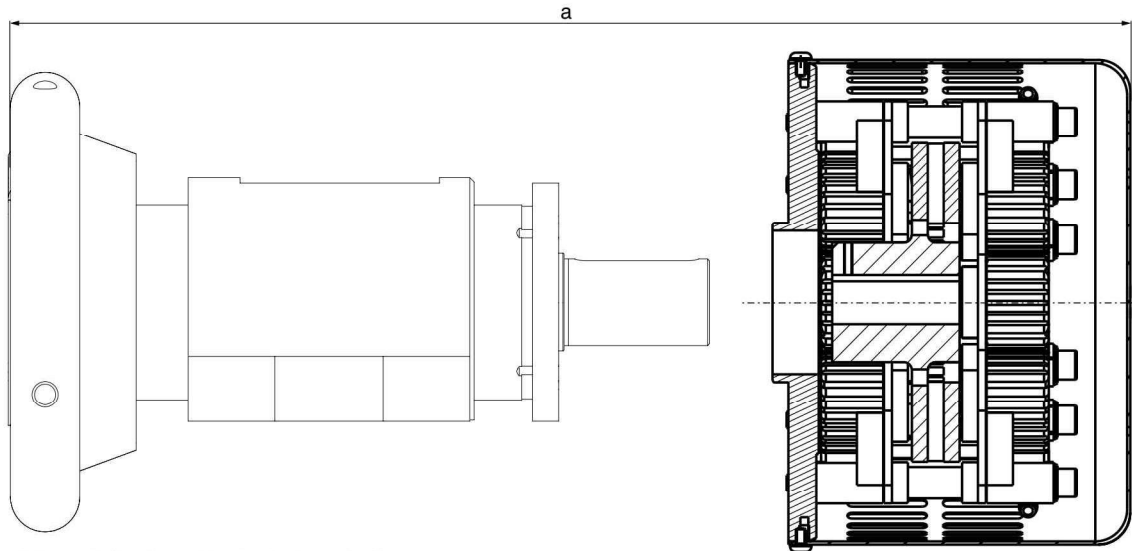

picture of chuck and brake just symbolic

overall dimension „a“
for Boschert Sliding-Chuck (flange- and foot mounted chuck)

	Multi			chuck dim. on pag
	500	1500	3000	
brake dim. on page	6.71	6.71	6.71	
Sliding-Chuck				
22-30				
50 mm adjustment	451	451	501	3.03 - 3.06
100 mm adjustment	551	551	601	3.03 - 3.06
30-40				
50 mm adjustment	454	454	504	3.03 - 3.06
100 mm adjustment	554	554	604	3.03 - 3.06
40-50				
50 mm adjustment	460	460	510	3.03 - 3.06
100 mm adjustment	560	560	610	3.03 - 3.06
A Chuck				
A40	340	340	390	4.21 - 4.22
A50	391	391	441	4.31 - 4.32
A80	469	469	519	4.41 - 4.42
P Chuck				
P40	408	408	458	4.61 - 4.62
P50	445	445	495	4.71 - 4.72

Multi performance diagrams type 500 / 1500 / 3000



Multi 500

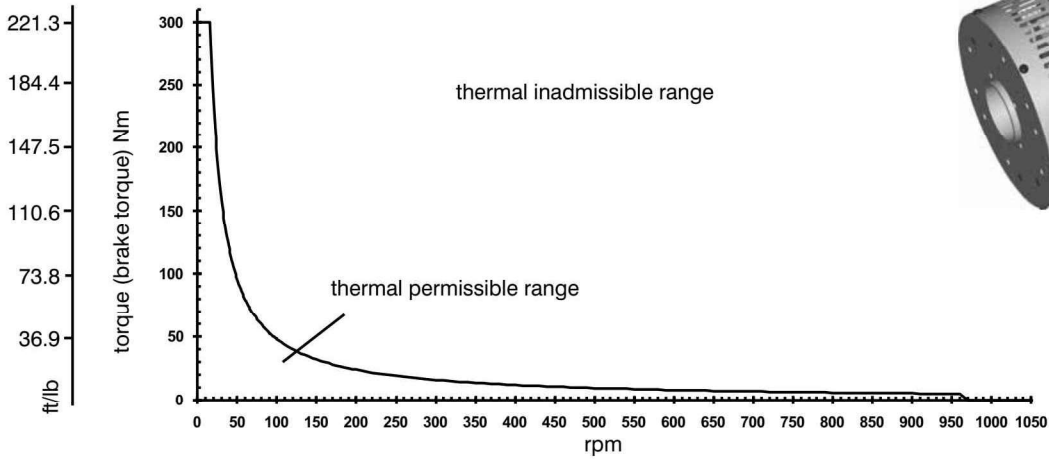

Multi 1500

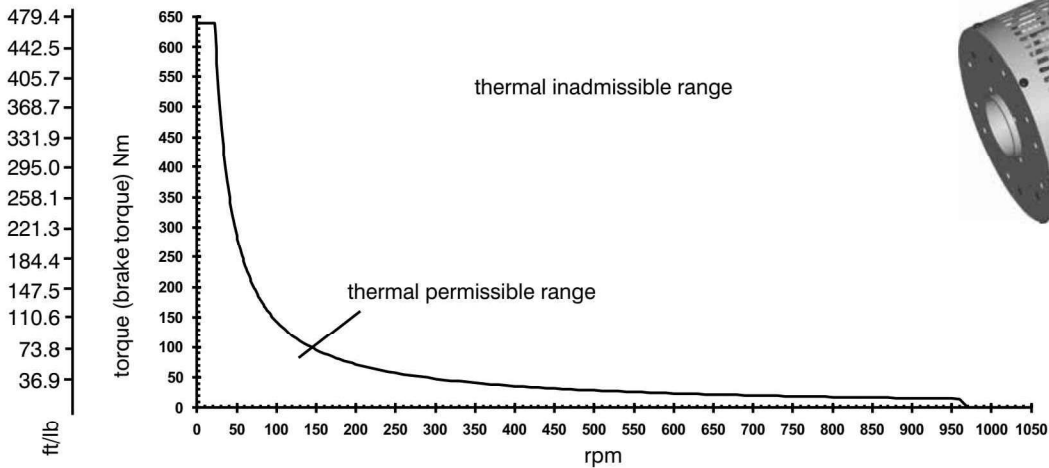

Multi 3000

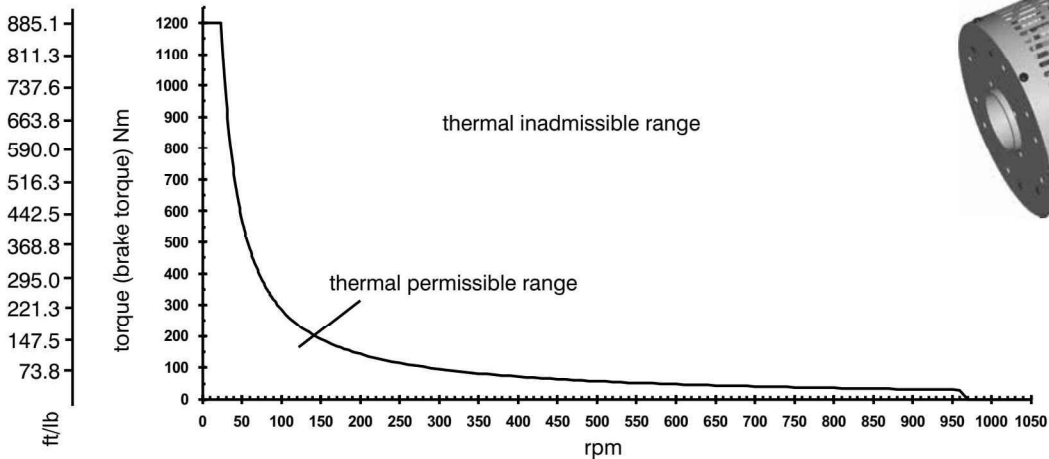

1 Nm = 0.7376 ft/lb

6.73

Mattenstrasse 1
D-79541 Loerrach-Hauingen

infokl@boschert.de
www.boschert.de

Tel.: +49 (0) 7621 / 9593 0
Fax: +49 (0) 7621 / 5518 4

Changes reserved (a)

MULTI wearing-parts

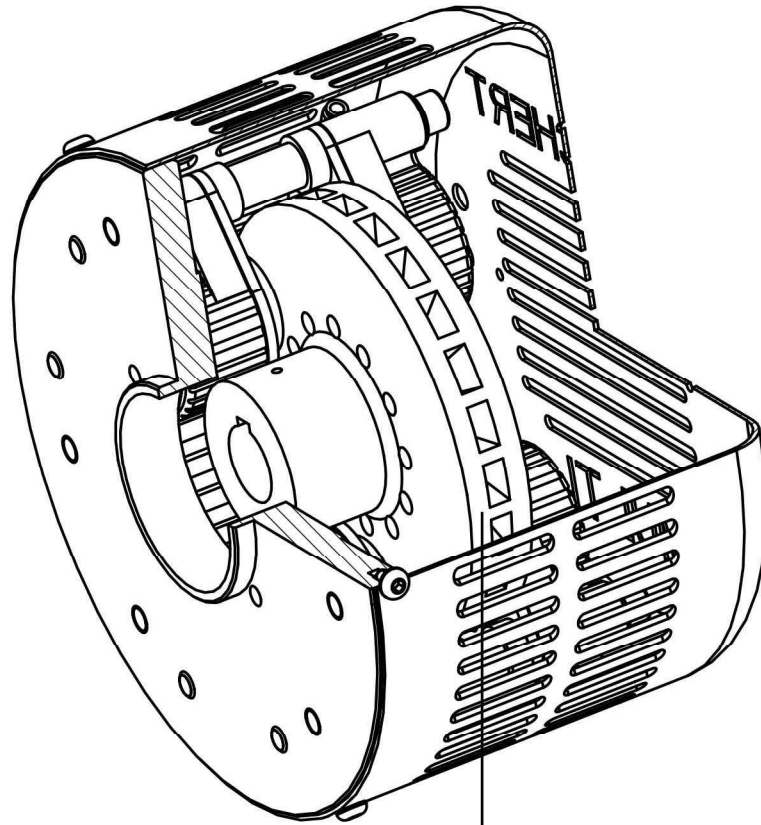

brake disc
Please note on your order:
- size of Safety Chuck
- size of brake

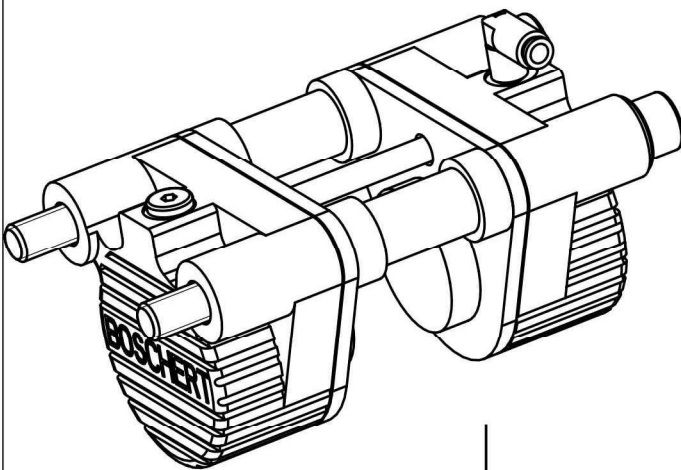

calliper BNR 18500002

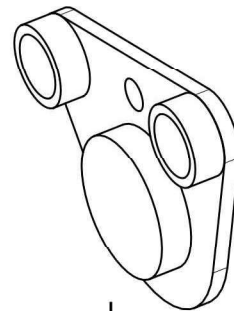

brake lining BNR 18500005-1

1 set brake linings = 2 pieces