

High-Integration 40A/70V Brushless DC Motor Controller with CAN or EtherCAT



Roboteq's SBLM13xx is a compact, full digital, high-performance and high-efficiency controller for Brushless DC motors. The controller supports a large selection of rotor position sensor types in order to generate smooth continuous rotation. The controller can be commanded via serial, USB, Analog or Pulse signals. Multiple controllers can be networked over a low-cost, twisted pair CANbus networks. For multi-axis applications requiring precise synchronized operation, the SBLM13xx can be fitted with an optional EtherCAT communication module.

The SBLM13xx uses the latest motion control technology, such as field-oriented control (FOC), acceleration/velocity feed forward, and fast loop frequency to deliver quick and precise motion control in speed, torque or position modes. Numerous safety features, including Safe Torque Off (STO) are incorporated into the controller to ensure reliable and safe operation.

The controller's operation can be extensively automated and customized using its built-in scripting language. The controller can be configured, monitored and tuned in real-time using a Roboteq's free PC utility. The controller can also be reprogrammed in the field with the latest features by downloading new operating software from Roboteq..

Applications

- Personal Mobility
- Machine Control
- Terrestrial and Underwater Robotic Vehicles
- Automatic Guided Vehicles
- Hazardous Material Handling Robots
- Telepresence Systems
- Animatronics
- Industrial Controls
- Hydraulic Pumps control

Key Features

- RS232, USB, 0-5V Analog, or Pulse command modes
- CANbus and optional EtherCAT fieldbus interfaces
- Optional RS485 (Special Order)
- Auto switch between Serial, CAN, EtherCAT, Analog, or Pulse based on user-defined priority
- Built-in 3-phase high-power drivers for one brushless DC motor at up to 40A with Higher than 98% Efficiency
- Support for 10 KOhm NTC temperature sensors through analog inputs (requires an external 10 KOhm pull-up resistor)
- Full forward & reverse motor control. Four quadrant operation. Supports regeneration
- Operates from a single power source up to 70V DC
- 40A Max, 20A continuous Current with I2T protection algorithm
- Programmable current limit up to 40A for protecting controller, motor, wiring and battery
- Trapezoidal switching based on Hall Sensor position information
- Smooth and quiet three Phase sinusoidal mode with Field Oriented Control
- High-Performance 16kHz Current Control loop
- Support for absolute angle encoders
 - Sin/Cos analog
 - SSI
 - Biss-C
 - Resolver
- CAN bus up to 1 Mbit/s. Multi-Protocol support
 - CANOpen DS402
 - RoboCAN Meshed Network
 - RawCAN Customizable to Any Protocol
- Optional EtherCAT Interface CANOpen over EtherCAT (CoE)

- Distributed Clocks with support up to 1kHz synchronization
- MODBUS ASCII and RTU Support over RS232 or RS485
- Locking Connectors for Communication, IO and Feedback Signals
- Accurate speed and Odometry measurement using Hall Sensor or encoder data
- Quadrature encoder input with 32-bit counter
- Up to six Analog Inputs for use as command and/or feedback
- Up to six Pulse Length, Duty Cycle or Frequency Inputs for use as command and/or feedback
- Up to six Digital Inputs for use as Dead-man Switch, Limit Switch, Emergency stop or user inputs
- Two general purpose 35V, 1.5A output for accessories
- 7A Max Output for regeneration brake resistor
- Adjustable PWM Output for motor brake
- Custom scripting in Basic language. Execution speed up to 100000 lines per second
- Selectable min/max, center and deadband in Pulse and Analog modes Selectable exponentiation factors for each command inputs
- Trigger action if Analog, Pulse, Encoder or Hall counter capture are outside user selectable range (soft limit switches)
- Open loop or closed loop speed control operation
- Closed loop position control with encoder, analog or pulse/frequency feedback
- Configurable Data Logging of operating parameters on Serial Outputs for telemetry or analysis
- Built-in Battery Voltage and Temperature sensors
- Connector for external Motor Windings Temperature sensor
- Optional 12-24V backup power input for powering safely the controller if the main motor batteries are discharged
- Power Control wire for turning On or Off the controller from external microcomputer or switch
- No consumption by output stage when motors stopped
- Regulated 5V-100mA output for powering sensors, RF Modem or microcomputer
- Stall detection and selectable triggered action if Amps is outside user-selected range
- Short circuit protection
- Over voltage and Under voltage protection
- Watchdog for automatic motor shutdown in case of command loss
- Over temperature protection
- Power and Diagnostic LED indicators
- Efficient heat sinking using conduction bottom plate. Operates without a fan in most applications
- Power wiring via High-Current carrying Faston Terminals
- 70mm x 70mm x 27mm
- -40° to +85° C operating environment
- Easy configuration, tuning and monitor using provided PC utility
- Easy configuration, tuning and monitoring using provided PC utility
- Field upgradeable software for installing latest features via the Internet

Orderable Product References

Reference	Amps	Volts	STO	CAN	EtherCAT
SBLM1370	40 Max / 20 Continuous	70	No	Yes	No
SBLM1370E	40 Max / 20 Continuous	70	No	No	Yes
SBLM1370T	40 Max / 20 Continuous	70	Yes	Yes	No
SBLM1370TE	40 Max / 20 Continuous	70	Yes	No	Yes

Warning

A dangerous uncontrolled motor runaway condition can occur due to various reasons, including, but not limited to: command or feedback wiring failure, configuration errors, faulty firmware, errors in user scripts or programs, or controller hardware failure.

Users must be aware that such failures can occur and must ensure the safety of their system under all conditions. Roboteq will not be held liable for any damage or injury resulting from product misuse or failure.

Important Note

All products are not serviceable. If damage is suspected, the item must be replaced rather than repaired.

Attempting to service or repair the product voids any existing warranty and may pose safety risks.

Consult customer support for more information on replacements.

Power Wires Identifications and Connections

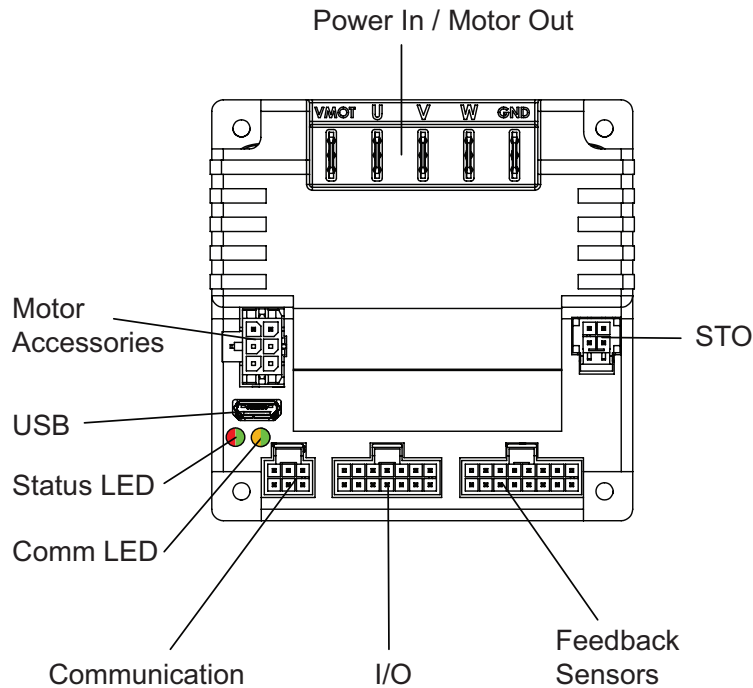

FIGURE 1. Controller Layout

Figure 2, below, shows how to wire the controller and how to turn power On and Off.

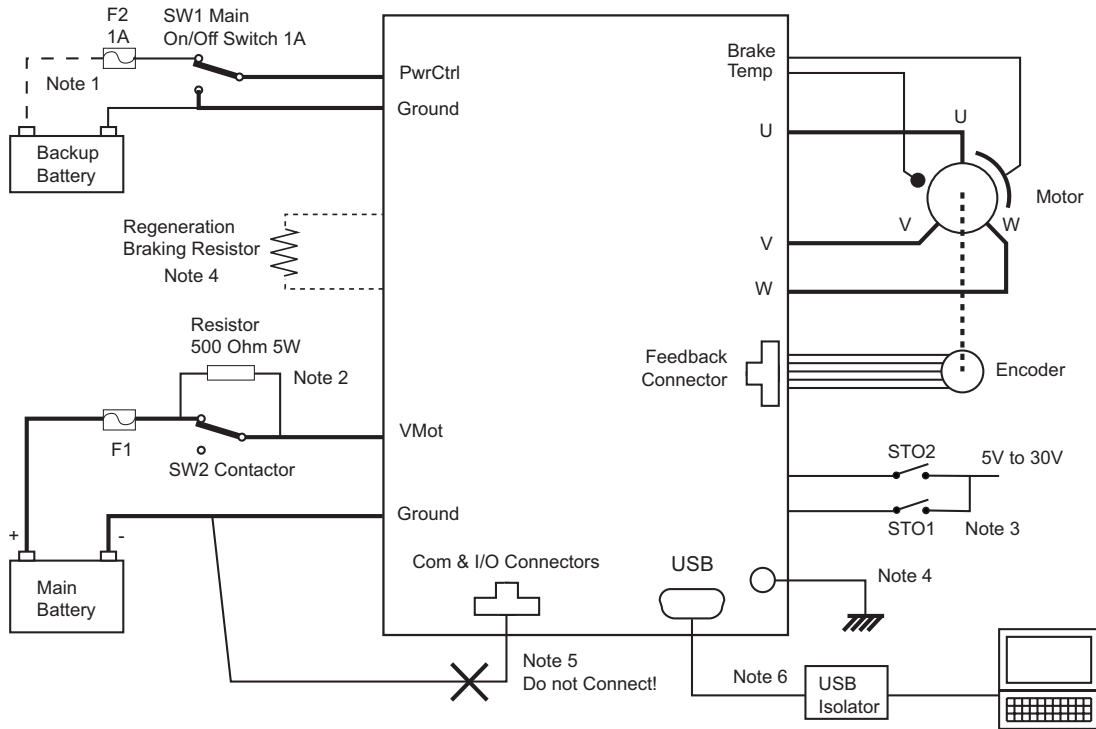

FIGURE 2. Powering the Controller. Thick lines identify **MANDATORY** connections

Caution

Carefully follow the wiring instructions provided in the Power Connection section of the User Manual. The information on this datasheet is only a summary.

Mandatory Connections

It is imperative that the controller is connected as shown in the above diagram in order to ensure a safe and trouble-free operation. All connections shown as thick black lines are mandatory.

Emergency Switch or Contactor

The battery must be connected in permanence to the controller's VMot tab via a high-power emergency switch or contactor SW2 as additional safety measure. The user must be able to deactivate the switch or contactor at any time, independently of the controller state. Use a suitable high-current fuse F1 as a safety measure to prevent damage to the wiring in case of major controller malfunction.

Power On/Off Switch

The **controller must be powered On/Off using switch SW1** on the Power Control pin.

Note 1: To ensure motor operation with weak or discharged batteries, connect a second battery to the Power Control pin via the SW1 switch. This will keep the controller alive and responding even if no voltage is present on the Vmot terminal.

Precharge Resistor

The controller has 400uF of internal capacitance which will cause a short duration but important current inrush the moment power is applied.

Note 2: If there is a concern that this current can overload the power supply or the contactor, insert a pre-charge resistors as shown in the figure. For precharging to take place, the controller must be turned off by grounding the Power Control pin.

Enable Safe Torque Off

Note 3: On versions of the controller with STO support, the Motor will be prevented from running until its STO inputs are both connected to a voltage of 5V or higher. If one or both STO lines are floated or grounded, the drive will be ON and able to communicate but the motor will not be driven. See details further down in this datasheet and in the User Manual.

Regeneration Protection and Braking

During rapid deceleration, the kinetic energy will cause regeneration current flow out of the motor, back to the power source. When using a battery, the current will recharge the battery and create a dynamic braking effect. When a power supply is used, current will not be able to flow back to the source. Without that return path, the regeneration will cause voltage to rise up to dangerous level for the electronics.

Note 4: An external resistor must be connected as shown, in order to dissipate the excess energy when using a power supply, or if current is otherwise blocked from returning to the battery.

Connection to Chassis

Note 5: For improved EMI immunity and reduce emissions, it is recommended to connect the controller's bottom plate to the system's chassis. Note that the integrated controller's ground is not DC electrically connected the plate. There is, however, a capacitor between the controller's ground and the bottom plate, and therefore AC conductivity.

Precautions When Connecting PC via USB

Note 6: Always use an USB isolator to protect the drive and the PC against possible electrical damage. When using a portable PC, operate it from battery to avoid accidental return ground path via the charger.

Motor Connections

Power and Motor Connections

Connection to the battery is made using a row of five 0.25" (6.3mm) Faston tabs. Use any Faston mating connector and with AWG10 wire (recommended).

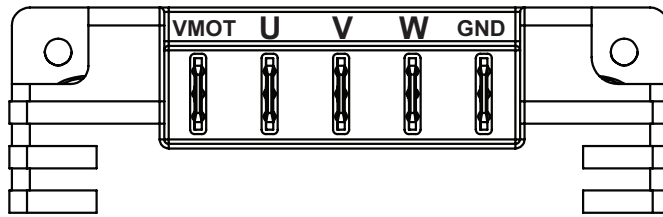

FIGURE 3. Power and Motor Connections

Motor Brake Connection

Two pins on the motor accessories connector are provided for connection to a mechanical motor brake. The output is modulated with a PWM signal so that a higher current can be initially applied to energize the coil, and then reduced to maintain the brake released while consuming less energy.

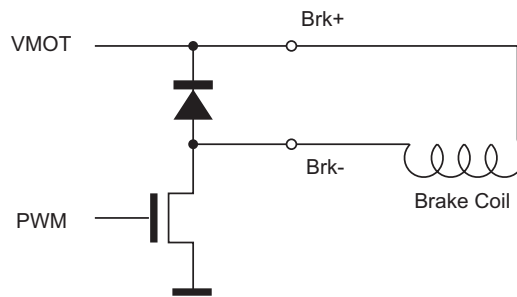

FIGURE 4. Mechanical Brake internal drive circuit and connection

Regeneration Brake Resistor Connection

Two pins on the motor accessories connector are provided for connecting a resistor. This resistor will burn off the motor's kinetic energy during rapid deceleration and must be installed in systems that are powered from power sources that cannot accept regeneration current.

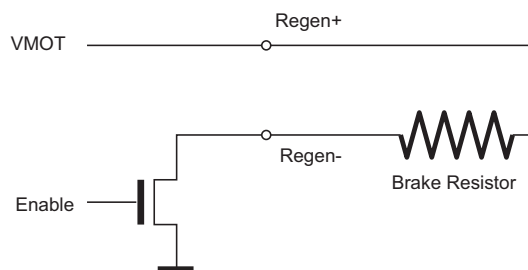

FIGURE 5. Regenerative Brake Resistor drive circuit and connection

The resistor value must be such that the current is under 5A at the Over voltage limit using the formula:

$$R \text{ (ohm)} = \text{Over voltage Limit (Volts)} / 5(\text{Amps})$$

The resistor value then determines the Power that will be burned during regeneration

$$P \text{ (Watts)} = \text{Over voltage Limit} * \text{Over voltage Limit (Volts)} / R \text{ (ohm)}$$

Example with 50V limit and 5A regen: R= 10 ohm, P=250W. This power will be dissipated for the duration of the braking.

Motor Accessories Connector

A six-pin Molex MicroFit connector provide the necessary connection to the mechanical brake, regeneration resistors and winding temperature sensor

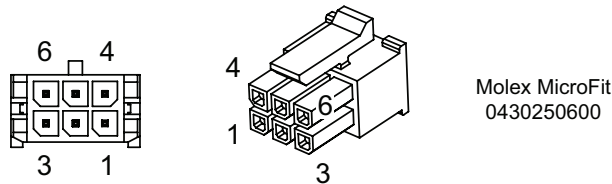

FIGURE 6. Motor Accessories Connector Pins Identification

TABLE 1.Pins identification

Connector Pin	Signal	Description
1	Regen Res+	Positive connection to Regen Brake Resistor. Internally connected to VMot.
4	Regen Res-	Regen Brake Resistor Switched connection to Ground
2	Motor Brake+	Positive connection to Mechanical Brake Coil. Internally connected to VMot
5	Motor Brake-	Mechanical Brake Switched connection to Ground
3	Temp+	NTC Temperature Sensor input+
6	Temp+	NTC Temperature Sensor Input-

Warning

The Brk+ and Regen+ are internally connected to the VMOT supply voltage. Exercise care to avoid short circuits during wiring.

Connecting Thermistors

A 10 KOhm NTC temperature sensor can be connected between the controller's Temp+ and Temp- inputs. This enables the reading of motor temperature through the controller's runtime variables and allows for active temperature protection. The controller has an integrated 10 KOhm pull-up resistor connected to 5V, so no additional resistor is required.

Low Power Signals Connections

The SBLM1360 uses five Molex Nanofit connectors for the low power signals. Each connector has a different size to avoid erroneous connection.

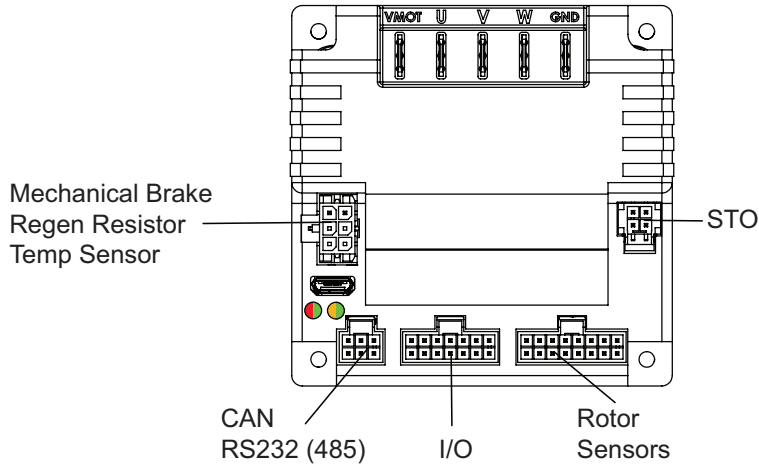

FIGURE 7. Connector Wiring Diagram

Communications Connector

Communication interface connector cable plug using a molex nanofit receptacle 1053081206

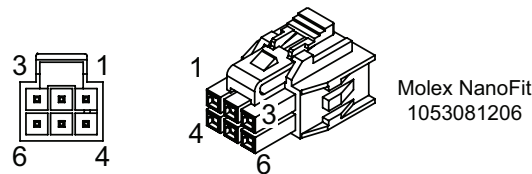

FIGURE 8. Communication Connector Pins Identification

TABLE 2. Pins Identification

Connector Pin	Signal	Description
1	CAN_H	CAN high bus line
4	CAN_L	CAN low bus line
2	RS232TxD	RS232 Transmit Data (RS485- Optional)
5	RS232RxD	RS232 Receive Data (RS485+ Optional)
3	GND	Ground
6	Shield	Cable Shield

The shield pin is not DC connected to the controller's ground. It is connected to ground via internal capacitors and thus provides an AC connection useful for EMI reduction.

Digital Feedback Sensors and I/O Connector

Digital rotor sensors signal must be wired to the 16-pin connector located in front of the controller. Some pins can alternatively be used as general purpose Analog, Digital or Pulse inputs. The functions of many pins vary depending on user configuration. Cable plug is using a molex microfit receptacle 1053081216

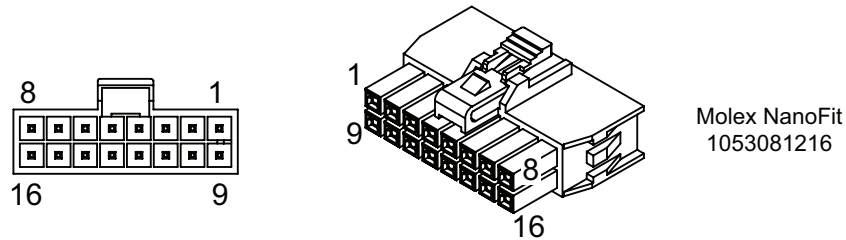

FIGURE 9. Connector Pin Locations

TABLE 3. Pins identification

Connector Pin	Power	Hall	Encoder	SSI	Analog In	Dinput	Pulse In
1	5VOut						
9	GND						
2		HallA+					
10		HallA- (1)					
3		HallB+					
11		HallB-					
4		HallC+		Clock-			
12		HallC-		Data-			
5			ENCA+		ANA1	DIN1	PIN1
13			ENCA- (1)				
6			ENCB+		ANA2	DIN2	PIN2
14			ENCB-				
7			ENCI+		ANA3	DIN3	PIN3
15			ENCI-				
8				Data+			
16				Clock+			

Note 1: Leave the minus (-) inputs unconnected when using single ended hall sensors or encoders

Analog Sensors and I/O Signal Connector

Analog rotor sensors signal must be wired to the 14-pin connector located in front of the controller. Some pins can alternatively be used as general purpose Analog, Digital or Pulse inputs. Two open drain digital outputs are also located on this connector. The functions of many pins vary depending on user configuration. Cable plug is using a molex microfit receptacle 1053081214.

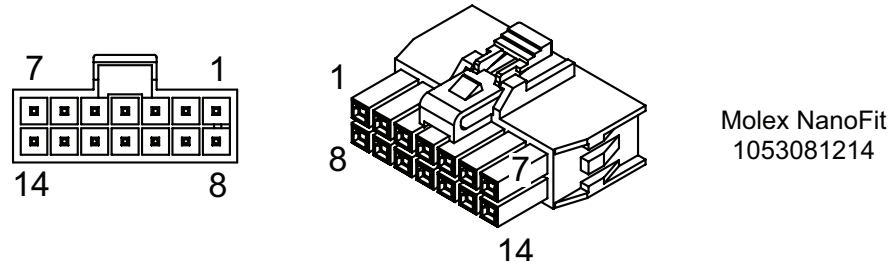

FIGURE 10. Connector Pin Locations

TABLE 4. Pins identification

Connector Pin	Power	Ana Sense	Ana Inputs	DInput	Pulse	DOutput
1						DOUT1
8						DOUT2
2		SIN+ (2)				
9		SIN- (3)				
3		COS+				
10		COS- (3)				
4			AIN4	DIN4	PIN4	
11		EXC- (4)				
5		EXC+ (4)				
12	GND					
6	PwrCtrl(1)					
13	GND					
7	5VOut					
14	GND					

Note 1: Ground this pin for turning off the controller

Note 2: Use SIN and COS inputs for Sin/Cos sensors and resolvers

Note 3: Connect SIN- and COS- to ground when using single-ended Sin/Cos sensors

Note 4: Use Excitation signals with Resolvers

Connecting Resolver

Resolver wiring is similar to a Sin/Cos sensor with the addition of an excitation signal. Diagram below shows the necessary connections.

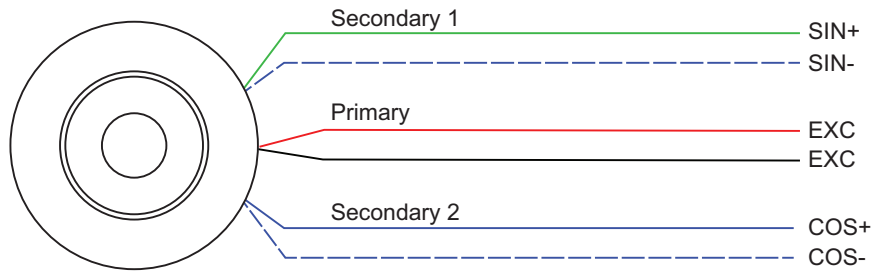

FIGURE 11. Resolver connections

Extra Inputs Connector (STO Connector)

On versions of the SBLM13xx without STO, the STO connector carries two Digital/Analog inputs signals. Connector cable plug is using a molex nanofit receptacle 1053081204

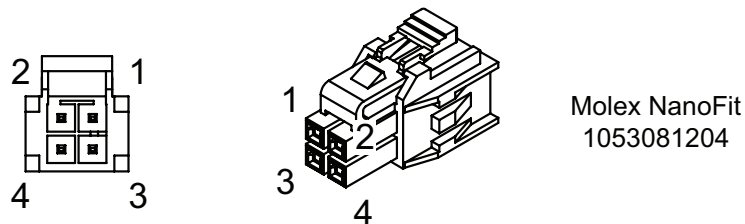

FIGURE 12. Extra Inputs Connector Pins Identification on STO connector

TABLE 5. Pins identification

Connector Pin	Power	Digital In	Analog In	Pulse In
1		DIN5	AIN5	PIN5
3		DIN6	AIN6	PIN6
2	GND			
4	GND			

Safe Torque Off - STO (Certification Pending)

Safe Torque Off is a safe method for switching controller in a state where no torque is generated, regardless whether the controller is operating normally or is faulty. When STO is enabled, two digital inputs, DIN5 and DIN6 are remapped as STO1 and STO2. The inputs are redundant and both must have a 6V to 30V signal present at the same time in order for the Power MOSFETs to be energized. The controller will perform a self-check of the STO circuit at every power on and every time the STO inputs go from any state to both

high. Once the STO hardware is verified to work, the controller will safely allow the motors to be energized. If either input is floated or below 1V, the controller's outputs will be disabled. The STO circuit is verified and validated and can therefore be trusted instead of external relays. See [STO Manual](#) for more information and maintenance instructions.

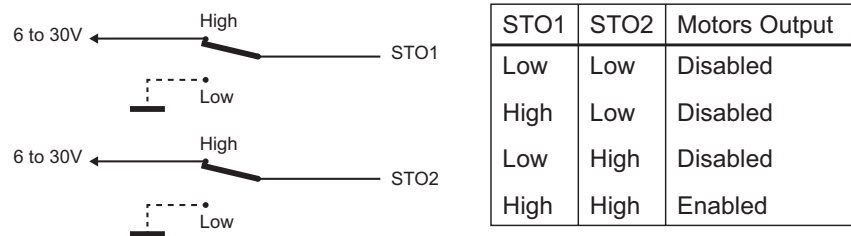

FIGURE 13. STO input levels effects on controller output

The STO function is compliant to:

- IEC 61800-5-2:2007, SIL 3
- IEC 61508:2010, SIL 3
- IEC 62061:2005, SIL 3
- ISO 13849-1:2015, Category 3 Performance Level e

Warning

Activating STO disables all torque generation on the motor. The motor free wheeling and not actively stopped.

Motor will not start if the pins on the STO connector are left floating.

STO Connector

This four-pin connector has the Safe Torque Off signals on controllers with the STO option. The STO signals can be also be read as Analog, Digital or Pulse input 5 and 6. The STO connector cable plug is using a molex nanofit receptacle 1053081204

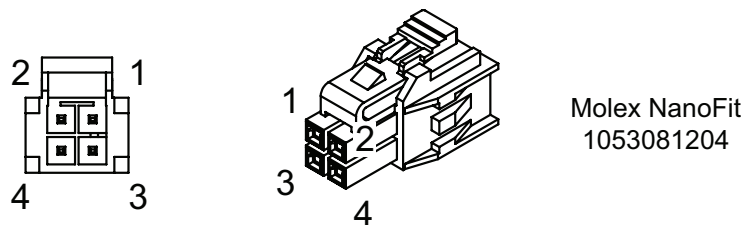

FIGURE 14. STO Connector Pins Identification

TABLE 6. Pins identification

Connector Pin	Power	STO Signal	Description
1		STO1	Connect both lines to 6-24V to Enable Motor
3		STO2	
2	GND		Ground
4	GND		Ground

CAN Communication

CAN is the SBLM13xx's primary and recommended communication interface. Up to 127 drives can be networked on a low cost twisted pair network up to 1000m long and at speeds up to 1Mbit/s. Roboteq support four CAN protocols:

- CANOpen for interoperability with other vendor's DS301 and DS402 compliant devices
- RoboCAN, a simple and effective peer to peer meshed network protocol
- MiniCAN, a simplified subset of CANOpen PDOs
- Raw CAN, a low-level system used with scripting for constructing and parsing CAN frames to handle any protocols

TABLE 7. CANOpen Communications Specification

Feature	Value
Motion Network type	CAN, CANOpen
CANOpen Standards Support	DS301, DS402
Operating Modes	cyclic sync torque, cyclic sync velocity, cyclic sync position, profile position, profile velocity, profile torque modes, homing
Process Data Objects (PDO)	Cyclic sync and free run modes. Cyclic messages can be set for 20 objects on 4 maps

EtherCAT Communication

The SBLM13xx is available in a version that supports the EtherCAT interface. EtherCAT is an Ethernet-based communication protocol for fast and precise synchronization in multi-drive, multi-axis systems. The controller supports CANOpen over EtherCAT (CoE), meaning that it shares the CANOpen DS402 object directory and operating modes.

Connections to the EtherCAT bus is done via two RJ45 connectors.

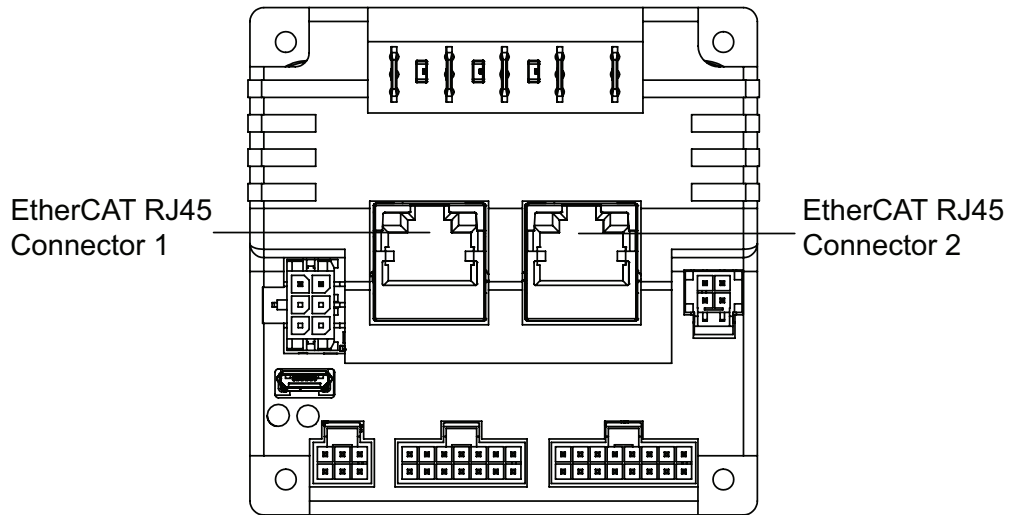

FIGURE 15. Connector Locations on optional EtherCAT version

USB communication

Use USB only for configuration, monitoring and troubleshooting. USB is not a reliable communication method when used in a electrically noisy environments and communication will not always recover after it is lost without unplugging and replugging the connector, or restarting the controller. Always prefer RS232 communication when interfacing to a computer.

Warning

Always use an USB isolator to protect the drive and the PC against possible electrical damage. When using a portable PC, operate it from battery to avoid accidental return ground path via the charger.

Status LED Flashing Patterns

After the controller is powered on, the Status LED will be flashing at a two seconds interval. The flashing pattern and color provides operating or exception status information. Additional status information may be obtained by monitoring the controller with the PC utility.



FIGURE 16. Status LED Normal Operation Flashing Patterns

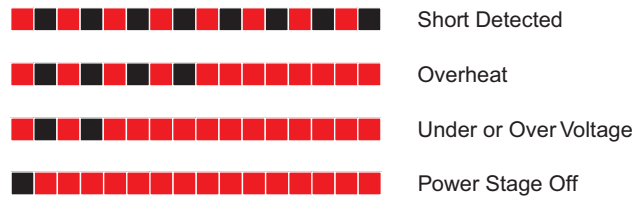

FIGURE 17. Status LED Exception or Fault Flashing Patterns

The communication LED gives status information on the CAN and USB. This LED is always ON with one color or the other when the controller is running

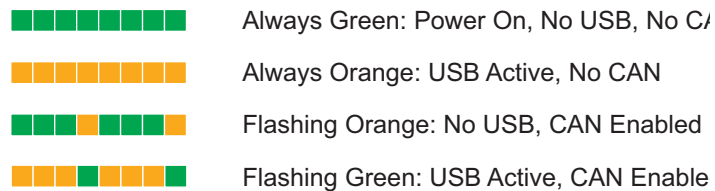

FIGURE 18. Power On and Communication LED

Electrical Specifications

Absolute Maximum Values

The values in Table 4, below, should never be exceeded. Permanent damage to the controller can occur.

TABLE 8.

Parameter	Measure point	Min	Typical	Max	Units
Battery Leads Voltage	Ground to VMot			70	Volts
Reverse Voltage on Battery Leads	Ground to VMot	-1			Volts
Power Control Voltage	Ground to Pwr Control wire			70	Volts
Motor Leads Voltage	Ground to U, V, W wires			70 (1)	Volts
Digital Output Voltage	Ground to Output pins			40	Volts
Analog and Digital Inputs Voltage	Ground to any signal pin			30	Volts
RS232 I/O pins Voltage	External voltage applied to Rx/Tx pins			30(2)	Volts
Case Temperature	Case	-40		85	°C
Humidity	Case			100 (3)	%

Note 1: Maximum regeneration voltage in normal operation. Never inject a DC voltage from a battery or other fixed source
 Note 2: No voltage must be applied to the RS232 Tx pin
 Note 3: Non-condensing

Electrostatic Discharge Protection

In accordance with IEC 61000-6-4, Roboteq Motor Controllers are designed to withstand ESD up to 4kV touch and 8kV air gap. This protection is implemented without any additional external connections required.

Some specifications, such as EN12895, require a higher level of protection. To maximize ESD protection, up to 8kV touch and 15kV air gap, you may connect the metallic heat sink of the controller to your battery negative terminal. [See App Note 062918 for example connections.](#)

Power Stage Electrical Specifications (at 25°C ambient)

TABLE 9.

Parameter	Measure point	Min	Typical	Max	Units
Battery Leads Voltage	Ground to VMot	0 (1)		70	Volts
Motor Leads Voltage	Ground to U, V, W wires	0 (1)		70 (2)	Volts
Power Control Voltage	Ground to Power Control wire	0 (1)		70	Volts
Minimum Operating Voltage	VMot or Pwr Ctrl wires	10 (3)			Volts
Over Voltage protection range	Ground to VMot	5	60 (4)	70	Volts
Under Voltage protection range	Ground to VMot	0	5 (4)	70	Volts
Idle Current Consumption	VMot or Pwr Ctrl wires	50	100 (5)	150	mA
ON Resistance (Excluding wire resistance)	VMot to U, V or W. Ground to U, V or W		4		mOhm
Max Current for 30s	Motor current			40	Amps
Continuous Max Current	Motor current			20 (7)	Amps
Current Limit range	Motor current	5	30 (8)	40	Amps
Stall Detection Amps range	Motor current	5	40 (8)	40	Amps
Stall Detection timeout range	Motor current	1	65000 (9)	65000	milliseconds
Short Circuit Detection threshold (10)	Between Motor wires or Between Motor wires and Ground		75		Amps
Short Circuit Detection threshold	Between Motor wires and VMot	No Protection. Permanent damage will result			
Motor Acceleration/Deceleration range	Motor Output	100	500 (11)	65000	milliseconds

Note 1: Negative voltage will cause a large surge current. Protection fuse needed if battery polarity inversion is possible

Note 2: Maximum regeneration voltage in normal operation. Never inject a DC voltage from a battery or other fixed source

Note 3: Minimum voltage must be present on VMot or Power Control wire

Note 4: Factory default value. Adjustable in 0.1V increments

Note 5: Current consumption is lower when higher voltage is applied to the controller's VMot or PwrCtrl wires

Note 6: Max value is determined by current limit setting. Duration is estimated and is dependent on ambient temperature cooling condition

Note 7: Estimate. Limited by heat sink temperature. Continuous current may be higher with better cooling

Note 8: Factory default value. Adjustable in 0.1A increments

Note 9: Factory default value. Time in ms that Stall current must be exceeded for detection

Note 10: Controller will stop until restarted in case of short circuit detection

Note 11: Factory default value. Time in ms for power to go from 0 to 100%

Command, I/O and Sensor Signals Specifications

TABLE 10.

Parameter	Measure point	Min	Typical	Max	Units
Main 5V Output Voltage	Ground to 5V pin on DSub15	4.7	4.9	5.1	Volts
5V Output Current	5V pin on I/O connectors			100	mA
Digital Output Voltage	Ground to Output pins			40	Volts
Digital Output Current	Output pins, sink current			1	Amps
Output On resistance	Output pin to ground		0.75	1.5	Ohm
Output Short circuit threshold	Output pin	1.05	1.4	1.75	Amps
Input Impedances	AIN/DIN Input to Ground		53		kOhm
Digital Input 0 Level	Ground to Input pins	-1		1	Volts
Digital Input 1 Level	Ground to Input pins	3		15	Volts
Analog Input Range	Ground to Input pins	0		5.1	Volts
Analog Input Precision	Ground to Input pins		0.5		%
Analog Input Resolution	Ground to Input pins		1		mV
Pulse durations	Pulse inputs	20000		10	us
Pulse repeat rate	Pulse inputs	50		250	Hz
Pulse Capture Resolution	Pulse inputs		1		us
Frequency Capture	Pulse inputs	100		2000	Hz
Encoder count	Internal	-2.147		2.147	10 ⁹ Counts
Encoder frequency	Encoder input pins			200	KHz
Note1: Encoders are disabled in factory default.					

Operating & Timing Specifications

TABLE 11.

Parameter	Measure Point	Min	Typical	Max	Units
Command Latency	Command to output change	0	0.5	1	ms
PWM Frequency	Motor outputs		16 (1)		kHz
Current Loop update rate	Internal		16000		Hz
Closed Loop update rate	Internal		1000		Hz
RS232/RS485 baud rate	Rx & Tx pins		115200 (2)		Bits/s
Command Watchdog timeout	Internal	1 (3)		65000	ms
Note 1: Frequency is fixed and cannot be changed					
Note 2: 115200, 8-bit, no parity, 1 stop bit, no flow control					
Note 3: May be disabled with value 0. Applies to commands from USB, RS232, RS485, CAN and EtherCAT					

Scripting

TABLE 12.

Parameter	Measure Point	Min	Typical	Max	Units
Scripting Flash Memory	Internal		32000		Bytes
Max Basic Language programs	Internal	1000		3000	Lines
Integer Variables	Internal			1024 4096(1)	Words (2)
Boolean Variables	Internal			8192	Symbols
Execution Speed	Internal	50 000	100 000		Lines/s
Note 1: 32-bit words					

Mechanical and Thermal Characteristics

Thermal Specifications

TABLE 13.

Parameter	Measure Point	Min	Typical	Max	Units
Board Temperature	PCB	-40		85 (1)	°C
Thermal Protection range	PCB	70		80 (2)	°C
Thermal resistance	Power MOSFETs to heats sink			2	°C/W
Note 1: Thermal protection will protect the controller power					
Note 2: Max allowed power out starts lowering at minimum of range, down to 0 at max of range					

Controller Mounting

During motor operation, the controller will generate heat that must be evacuated. The published amps rating can only be fully achieved if adequate cooling is provided. For best results, attach firmly with thermal compound paste against a metallic chassis so that heat transfers to the conduction plate to the chassis or metallic enclosure. If no metallic surface is available, mount the controller on spacers so that forced or natural air flow can go over the plate surface to remove heat.

Mechanical Specifications

TABLE 14.

Parameter	Measure Point	Min	Typical	Max	Units
Weight	Board		96 (.21)		g (lbs)
Power Wire Gauge	FastOn			10	AWG
Torque	D-sub standard connector		0.4 (3.54)		Nm (in-lbs)
Torque	Terminal block		0.8 (7.10)		Nm (in-lbs)
Torque	Mounting screws (4/M2.5)		0.36 (3.2)		Nm (in-lbs)

Mechanical Dimensions

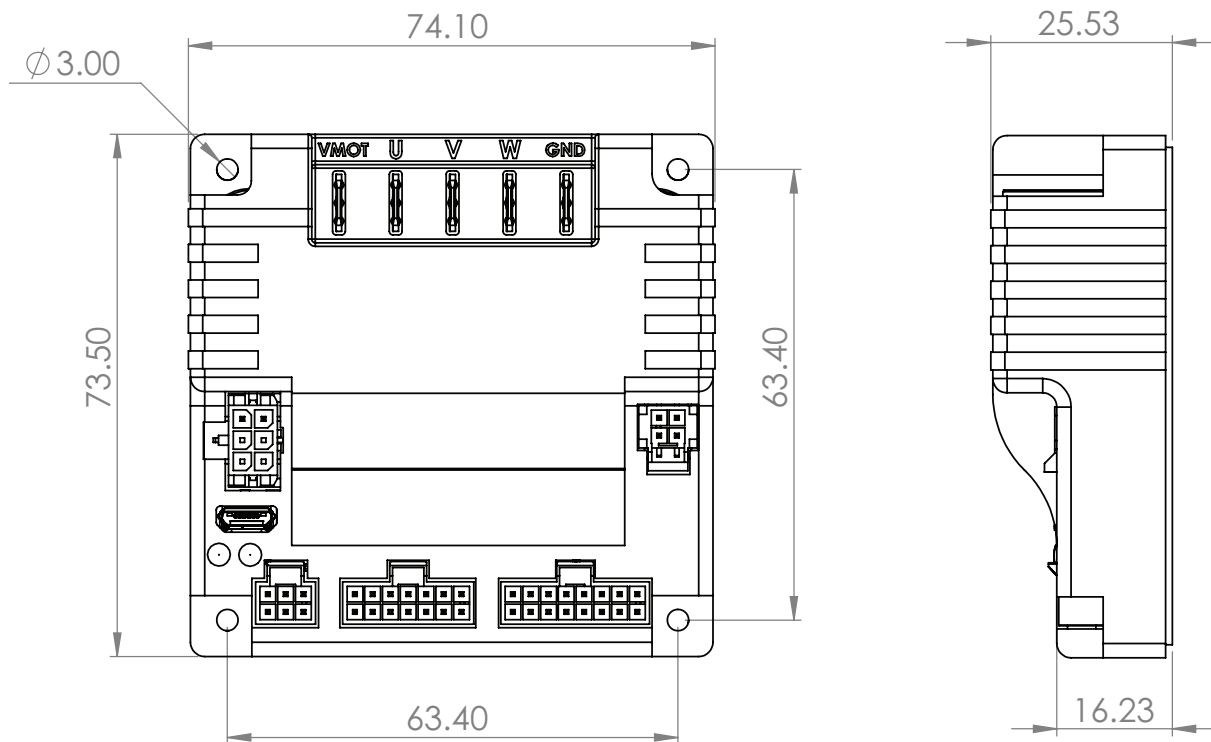

FIGURE 19. SBLM13xx Front View and Dimensions