

## Advanced Features Triple Channel 20A Brushed DC Motor Controller with USB and CAN



Roboteq's SDC3260 is a feature-packed, high-current, triple channel controller for brushed DC motors. The controller features a high-performance 32-bit microcomputer and quadrature encoder inputs to perform advanced motion control algorithms. The motors can be operated in open or closed loop speed mode, position mode or in torque mode.

The SDC3260 features several Analog, Pulse and Digital I/Os which can be remapped as command or feedback inputs, limit switches, or many other functions. The SDC3260 accepts commands received from an RC radio, Analog Joystick, wireless modem, PLC, or microcomputer. For mobile robotic applications, two of the controller's three motor channels can either be operated independently or mixed to move and steer a vehicle. Using CAN bus, up to 127 controllers can be networked at up to 1Mbit/s on a single twisted pair.

Numerous safety features are incorporated into the controller to ensure reliable and safe operation. The controller's operation can be extensively automated and customized using Basic Language scripts. The controller can be configured, monitored and tuned in real-time using a Roboteq's free PC utility. The controller can also be reprogrammed in the field with the latest features by downloading new operating software from Roboteq.

### Applications

- Motion simulators
- XYZ platforms
- Underwater Robotic Vehicles
- Stabilization Gimbals
- Machine tools
- Industrial automation
- Telepresence Systems
- Animatronics

### Key Features

- USB, RS323, RS485, 0-5V Analog, or Pulse (RC radio) command modes
- CAN bus interface up to 1Mbit/s with multiple protocol support
- Auto switch between Serial, USB, CAN, Analog, or Pulse based on user-defined priority
- Built-in triple high-power drivers for three brushed DC motor at up to 20A each
- Support for 10 KOhm NTC temperature sensors through analog inputs (requires an external 10 KOhm pull-up resistor)
- Full forward and reverse motor control. Four quadrant operation. Supports regeneration
- Operates from a single 10V-60V power source
- STO - Safe Torque Off support (T-version)
- Programmable current limit up to 20A per motor for protecting controller, motor, wiring and battery
- Separate connectors for three quadrature encoders
- Up to 8 Analog Inputs for use as command and/or feedback
- Up to eight Pulse Length, Duty Cycle or Frequency Inputs for use as command and/or feedback
- Up to 10 Digital Inputs for use as Deadman Switch, Limit Switch, Emergency stop or user inputs
- Four general purpose 24V, 1.5A output for brake release or accessories
- Selectable min/max, center and deadband in Pulse and Analog modes
- Selectable exponentiation factors for each command inputs
- Trigger action if Analog, Pulse or Encoder counter capture are outside user selectable range (soft limit switches)

- Open loop or closed loop speed control operation
- Closed loop position control with encoder, analog or pulse/frequency feedback
- Torque mode
- PID control loop
- Built-in Battery Voltage and Temperature sensors
- Optional backup power input for powering safely the controller if the main motor batteries are discharged
- Power Control wire for turning On or Off the controller from external microcomputer or switch
- No consumption by output stage when motors stopped
- Regulated 5V output for powering RC radio, RF Modem, sensors or microcomputer
- Separate Programmable acceleration and deceleration for each motor
- Ultra-efficient 3.3 mOhm ON resistance MOSFETs
- Selectable triggered action if Amps is outside user-selected range
- Short circuit protection
- Overvoltage and Undervoltage protection
- Watchdog for automatic motor shutdown in case of command loss
- Overtemperature protection
- Diagnostic LED indicators
- Efficient heat sinking. Operates without a fan in most applications.
- Dustproof and weather resistant. IP40 rating
- Power wiring using screw terminals
- 4.8" (123.0mm) L, 3.3" W (83.0mm), 1.0" (25mm) H
- -40° to +85° C operating environment
- Weight: 0.47 lbs (215g)
- Easy configuration, tuning and monitor using provided PC utility
- Field upgradeable software for installing latest features via the Internet Orderable Product References

### Orderable Product References

Reference	Number of Channels	Amps/Channel	Volts	STO
SDC3260	3	20	60	No
SDC3260T	3	20	60	Yes

**Warning**

A dangerous, uncontrolled motor runaway condition can occur for a number of reasons, including, but not limited to: command or feedback wiring failure, configuration error, faulty firmware, errors in user script or user program, or controller hardware failure.

The user must assume that such failures can occur and must make their system safe in all conditions. Roboteq will not be liable in case of damage or injury as a result of product misuse or failure.

**Important Note**

All products are not serviceable. If damage is suspected, the item must be replaced rather than repaired.

Attempting to service or repair the product voids any existing warranty and may pose safety risks.

Consult customer support for more information on replacements

**Power Wires Identifications and Connection**

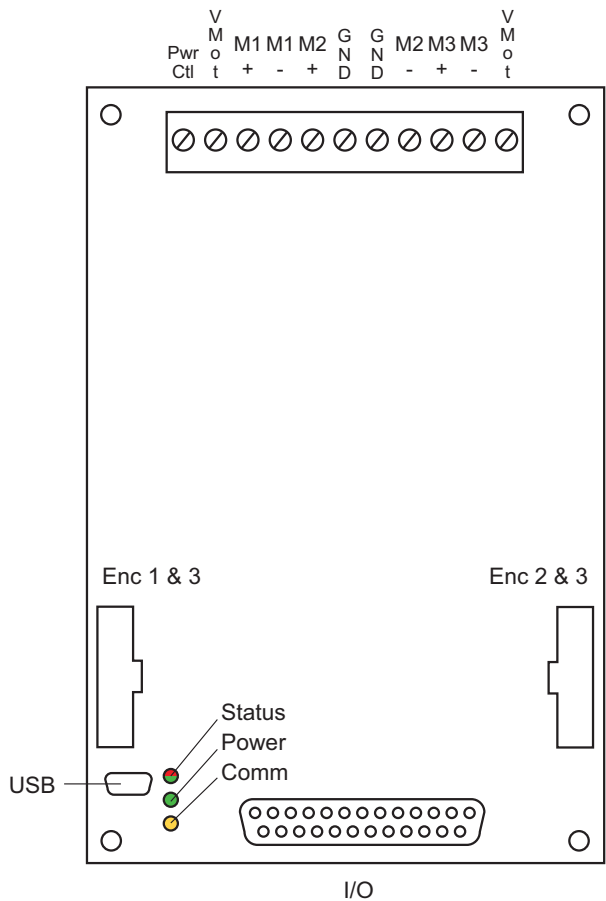

FIGURE 1. SDC3260 Outline

Figure 2, below, shows how to wire the controller and how to turn power On and Off.

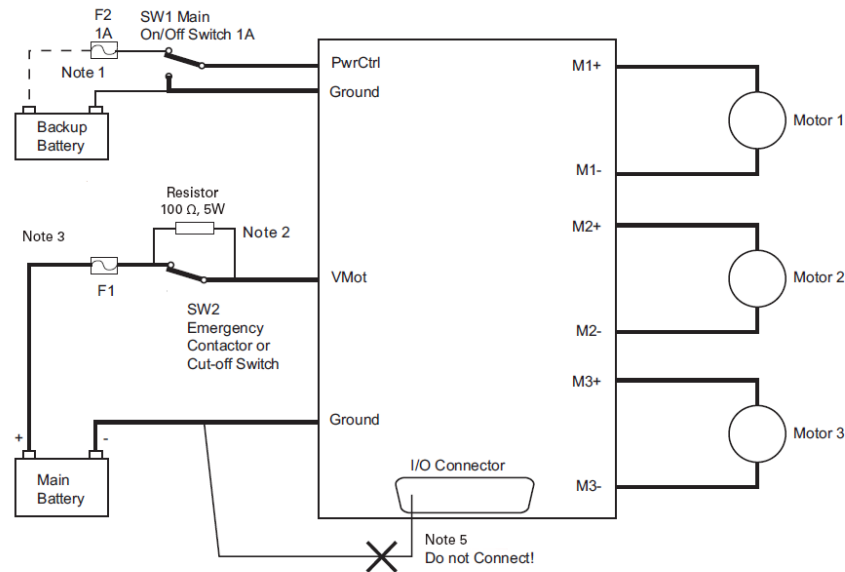

FIGURE 2. Powering the Controller. Thick lines identify MANDATORY connections

## Caution

Carefully follow the wiring instructions provided in the Power Connection section of the User Manual. The information on this datasheet is only a summary.

## Mandatory Connections

It is imperative that the controller is connected, as shown in the above diagram above, in order to ensure a safe and trouble-free operation. All connections shown as thick black lines are mandatory. The controller must be powered On/Off using switch SW1 on the Pwr Ctrl terminal. Use a suitable high-current fuse F1 (check table 9) as a safety measure to prevent damage to the wiring in case of major controller malfunction.

## Emergency Switch or Contactor

The battery must be connected in permanence to the controller's VMot terminal via a high-power emergency switch or contactor SW2 as additional safety measure. The user must be able to deactivate the switch or contactor at any time, independently of the controller state.

## Electrostatic Discharge Protection

In accordance with IEC 61000-6-4, Roboteq Motor Controllers are designed to withstand ESD up to 4kV touch and 8kV air gap. This protection is implemented without any additional external connections required.

Some specifications, such as EN12895, require a higher level of protection. To maximize ESD protection, up to 8kV touch and 15kV air gap, you may connect the metallic heatsink of the controller to your battery negative terminal. [See App Note 062918 for example connections.](#)

### Precautions and Optional Connections

Note 1: Backup battery to ensure motor operation with weak or discharged batteries, connect a second battery to the Power Control wire/terminal via the SW1 switch.

Note 2: Use precharge 100Ω, 5W Resistor to prevent switch arcing.

Note 3: The voltage generated by motors rotating while not powered by the controller can cause serious damage even if the controller is Off or disconnected.

- Use the main SW1 switch on the Power Control wire/terminal to turn Off and keep Off the controller. In this way the controller cannot be powered up under any unwanted circumstances.
- Countermeasures should be taken to deal with any regeneration power if the battery or BMS system does not support energy to return back to it.
- Disconnecting the controller from the battery while motors are rotating could lead to a serious damage. In this case a regeneration brake system is needed.

Note 4: Connect the controller's bottom plate to a wire connected to the Earth while the charger is plugged in the AC main, or if the controller is powered by an AC power supply.

Note 5: Beware not to create a path from the ground pins on the I/O connector and the battery minus terminal.

### Use of Safety Contactor for Critical Applications

An external safety contactor must be used in any application where damage to property or injury to person can occur because of uncontrolled motor operation resulting from failure in the controller's power output stage.

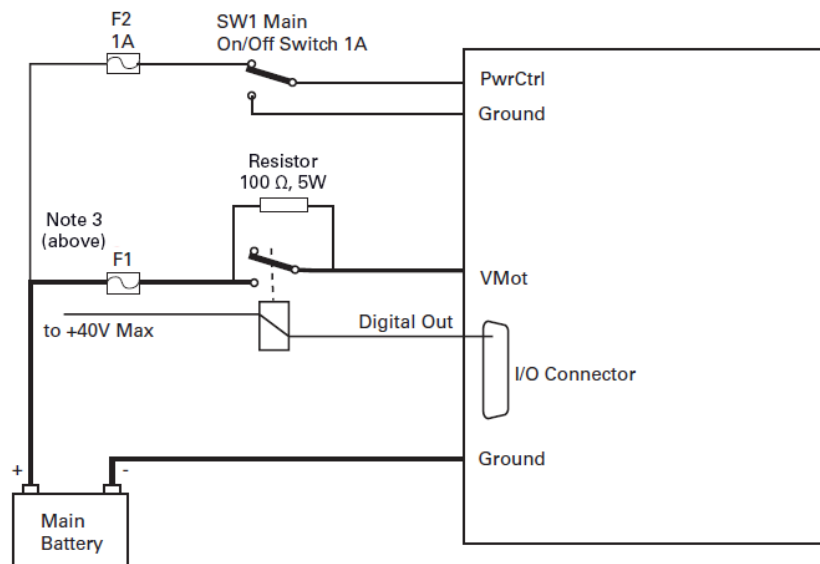

FIGURE 3. Contactor Wiring Diagram

The contactor coil must be connected to a digital output configured to activate when “No MOSFET Failure.” The controller will automatically deactivate the coil if the output is expected to be off and battery current of 1A or more is measured for more than 0.5s. This circuit will not protect against other sources of failure such as those described in the “Warning” on Page 3.

## Controller Mounting

During motor operation, the controller will generate heat that must be dissipated. The published amps rating can only be fully achieved if adequate cooling is provided. Good conduction cooling can be achieved by mounting the controller to a metallic surface, such as the chassis, cabinet. The mounting has to be like that, so that the thermal-safety limits are not exceeded.

## Encoder Connection

Connection to the Encoders is done using two special connectors on the front side of the controller. The connectors are 6-pin Molex Microfit 3.0, ref. 43645-0600. Pin assignments are in the table below.

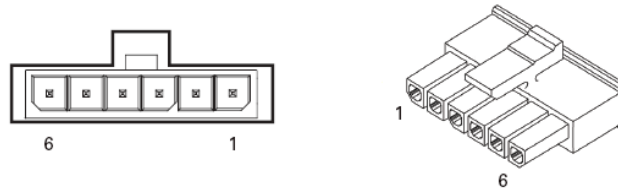

FIGURE 4. Encoder Connector

TABLE 1.

Pin Number	1	2	3	4	5	6
Connector 1	Ground	Enc1 A	Enc1 B	Enc3 A		5V
Connector 2	Ground	Enc2 A	Enc2 B	Enc3 B		5V

## Connection to SSI Absolute Encoder

The controller can use motors equipped with absolute angle sensors with SSI interface. When enabled, the SSI signals are found on the 6-pin Molex connectors that is otherwise used for encoders. The controller issues a differential clock signal and expects a up to 16-bit differential data signal from the encoder. Serial data from each sensor is captured on separate input pins.

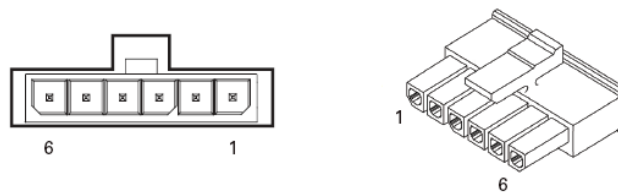

FIGURE 5. Encoder Connector

TABLE 2.

Pin Number	1	2	3	4	5	6
Signal	Ground	Data +	Data –	Clock –	Clock +	5V

## Commands and I/O Connections

Connection to RC Radio, Microcomputer, Joystick and other low current sensors and actuators is done via the 25 connector. The functions of many pins vary depending on controller model and user configuration. Pin assignment is found in the table below.

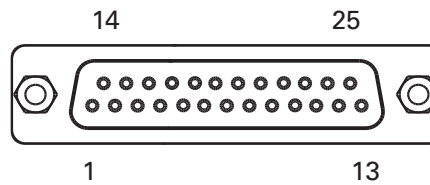

FIGURE 6. Main Connector Pin Locations

TABLE 3.

Connector Pin	Power	Dout	Com	Pulse	Ana	Dinput	Enc(4)	Default Config
1	GND							
14	5VOut							
2			RSTxD					RS232Tx
15				RC1	ANA1	DIN1		RCRadio1(3)
3			RS RxD					RS232Rx
16				RC2	ANA2	DIN2		RCRadio2(3)
4				RC3 (6)	ANA3	DIN3/ STO1(2)		AnaCmd1 (1)
17				RC4 (6)	ANA4	DIN4/ STO2(2)		AnaCmd2 (1)
5	GND							
18		DOUT1						Motor Brake 1
6		DOUT2						Motor Brake 2
19		DOUT3						Contactors
7		DOUT4						Unused
20			CANH					Unused
8			CANL					Unused
21				RC5	ANA5	DIN5	ENC2A (5)	Unused
9								Unused
22				RC6	ANA6	DIN6	ENC2B (5)	Unused
10								Unused
23			RS485+					RS485+
11			RS485–					RS485–

TABLE 3.

Connector Pin	Power	Dout	Com	Pulse	Ana	Dinput	Enc(4)	Default Config
24				RC7	ANA7	DIN7	ENC1A (5)	Unused
12				RC8	ANA8	DIN8	ENC1B (5)	Unused
25	5VOut							
13	GND							

Note 1: Analog command is disabled in factory default configuration.  
 Note 2: STO functionality only available in T versions. See STO section for details.  
 Note 3: Pulse input enable by default on firmware version prior to v2.0  
 Note 4: Enc inputs are activated in DB25 connector in firmware v2.0 or later and only if Molex input is configured as SSI Input. In that case user has to install 1K pull up resistor between each enc signal and 5VOut.  
 Note 5: When Encoder 1 and 2 are enabled in D-sub connector no other function is available on those pins.  
 Note 6: Not recommended for MultiPWM on T versions.

### Default I/O Configuration

While the controller can be configured so that practically any Digital, Analog or RC pin can be used for any purpose, the controller’s factory default configuration provides an assignment that is suitable for most applications. The figure, below, shows how to wire the controller to two analog potentiometers, an RC radio, and the RS232 port. It also shows how to connect two outputs to motor brake solenoids and another output to an external status LED. You may omit any connection that is not required in your application. The controller automatically arbitrates the command priorities depending on the presence of a valid command signal in the following order: 1-RS232, 2-RC Pulse, 3-None. If needed, use the Roborun+ PC Utility to change the pin assignments and the command priority order.

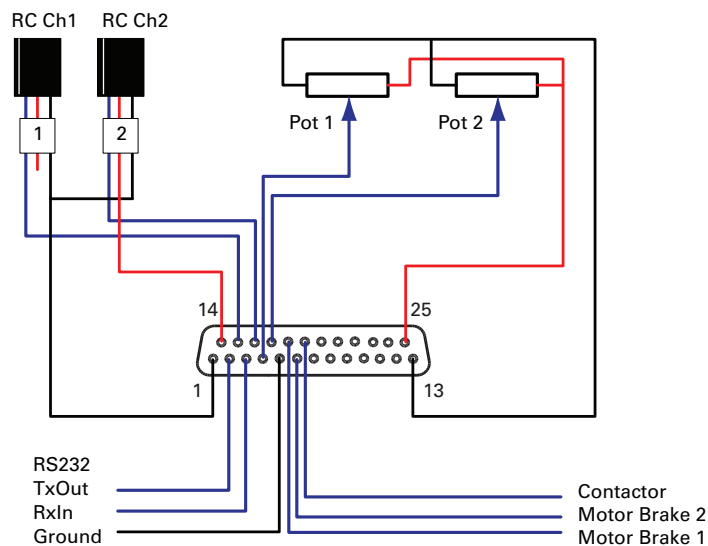

FIGURE 7. Factory Default Pin Assignments



---

## Enabling Analog Commands

For safety reasons, the Analog command mode is disabled by default. To enable the Analog mode, use the PC utility and set Analog in Command Priority 2 or 3 (leave Serial as priority 1). Note that by default the additional securities are enabled and will prevent the motor from starting unless the potentiometer is centered, or if the voltage is below 0.25V or above 4.75V. The drawing shows suggested assignment of Pot 1 to ANA1 and Pot 2 to ANA4. Use the PC utility to enable and assign analog inputs.

---

## Connecting Thermistors

10 KOhm NTC temperature sensors can be connected to the controller's analog inputs. This enables reading of motor temperature through the controller's runtime variables and allows for active temperature protection. This connection can be achieved by using a 10 KOhm pull-up resistor between the analog input and the controller's 5V output. For more information about motor temperature readings and controller parameterization, please refer to the Roboteq Controller's User Manual.

---

## USB communication

Use USB only for configuration, monitoring and troubleshooting the controller. USB is not a reliable communication method when used in electrically noisy environments. Further, communication will not always recover after it is lost without unplugging and replugging the connector, or restarting the controller. RS232 communication is always preferred when interfacing to a computer. USB and CAN will operate at the same time on the SDC3260. Connecting to a computer via the USB will not disable the CAN interface.

---

## RS485 Communication

RS485 is an industry standard for defining serial communication. Due to its balanced signaling, RS485 is effective over distances, even if other electrical signals are present. Its stability makes it well suited for connecting multiple receivers to a single network.

You can operate RS485 in half-duplex mode and it is well suited for use with the Modbus protocol. On the 25-pin connector, 2-pins are present.

---

## Important Note

**In some models, RS485 communication requires two 10 kΩ resistors to be connected to the A and B signals of the bus as follows:**

- **One resistor should be connected from the A signal to the controller's 5V output.**
- **One resistor should be connected from the B signal to the controller's ground.**

## Status LEDs and Flashing Patterns

The controller is equipped with 3 LEDs. A Green Power LED, a Red/Green Status LED, and a Yellow Communication LED. After the controller is powered on, the Power LED will turn on, indicating that the controller is On. The Status LED will be flashing at a 2 seconds interval. The flashing pattern and color provides operating or exception status information.

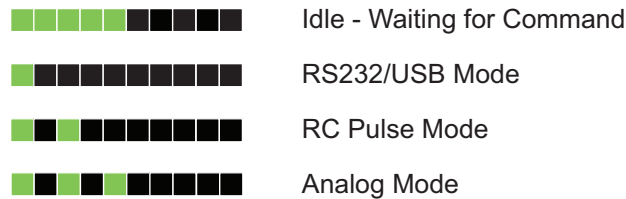

FIGURE 8. Normal Operation Flashing Patterns

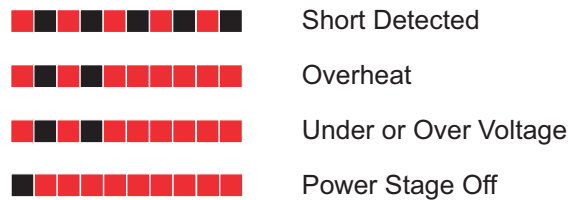

FIGURE 9. Exception or Fault Flashing Patterns

Additional status information may be obtained by monitoring the controller with the PC utility.

The communication LED gives status information on the CAN and USB.

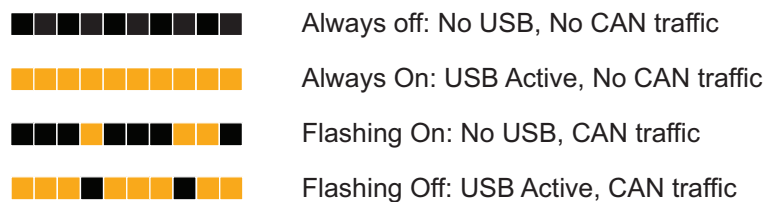

FIGURE 10. Communication LED Flashing Patterns

## Measured Amps

The controller includes Amps sensors in line with the motor terminals and on the battery ground terminals. Both Motor Amps and Battery Amps are therefore measured with precision.

## Safe Torque Off - STO

Safe Torque Off is a safe method for switching controller in a state where no torque is generated, regardless whether the controller is operating normally or is faulty. When STO is enabled, two digital inputs, DIN3 and DIN4 are remapped as STO1 and STO2. The inputs are redundant and both must have a 6V to 30V signal present at the same time in order for the Power MOSFETs to be energized. The controller will perform a self-check of the STO circuit at every power on and every time the STO inputs go from any state to both high. Once the STO hardware is verified to work, the controller will safely allow the motors to be energized. If either input is below 1V, the controller's outputs will be disabled. The STO circuit is verified and validated and can therefore be trusted instead of external relays. See [STO Manual](#) for more information and maintenance instructions.

By factory default STO functionality is disabled. It must be enabled by removing the jumper located on the controller's PCB. STO functionality is only available in the T version of the controller.

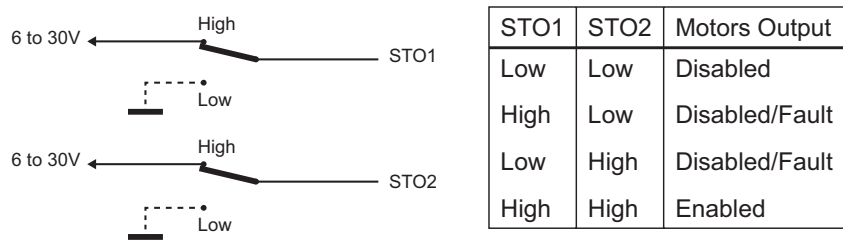

FIGURE 11. STO input levels effects on controller output

The STO function is compliant to:

- IEC 61800-5-2:2007, SIL 3
- IEC 61508:2010, SIL 3
- IEC 62061:2005, SIL 3
- ISO 13849-1:2015, Category 3 Performance Level e

## Warning

**Activating STO causes the motor to float and cease torque generation. Since the motor will not be actively braked, it will decelerate solely due to the system's friction. In mobile robot applications, the robot may continue moving for several meters before coming to a complete stop. For safe operation, additional braking measures should be implemented when STO is enabled, such as utilizing a mechanical or electrical brake. Roboteq offers one solution in the form of the SBSxxxx Safety Electric Brake Switch series, which quickly stops the motor by shorting its phases when STO is triggered.**

## Electrical Specifications

### Absolute Maximum Values

The values in the table below should never be exceeded, permanent damage to the controller may result.

TABLE 4.

Parameter	Measure point	Min	Typ	Max	Units
Battery Leads Voltage	Ground to VBat			60 (2)	Volts
Reverse Voltage on Battery Leads	Ground to VBat	-1			Volts
Power Control Voltage	Ground to Pwr Control wire			60 (2)	Volts
Motor Leads Voltage	Ground to U, V, W wires			60 (2)	Volts
Digital Output Voltage	Ground to Output pins			30	Volts
Analog and Digital Inputs Voltage	Ground to any signal pin on 15-pin & Hall inputs			30	Volts
RS232 I/O pins Voltage	External voltage applied to Rx pin			30 (3)	Volts
Case Temperature	Case	-40		85	°C
Humidity	Case			100 (4)	%
Note 1: Only PELV/SELV voltages shall be used					
Note 2: Can be even higher because of regeneration voltage. Never inject a DC voltage from a battery or other fixed source					
Note 3: No voltage must be applied on Tx pin					
Note 4: Non condensing					

### Power Stage Electrical Specifications (at 25°C ambient)

TABLE 5.

Parameter	Measure point	Model	Min	Typ	Max	Units
Battery Leads Voltage	Ground to VMot	All	0 (1)		60	Volts
Input Continuous current	Power source current	All			40	Amps
Output Voltage	Ground to U, V, W wires	All	0 (1)		60 (2)	Volts
Power Control Voltage	Ground to Power Control wire	All	0 (1)		65	Volts
Minimum Operating Voltage	VBat or Pwr Ctrl wires	All	10 (3)			Volts
Over Voltage protection range	Ground to VMot	All	5	60 (4)	63	Volts
Under Voltage protection range	Ground to VMot	All	0	5 (4)	63	Volts
Idle Current Consumption	VMot or Pwr Ctrl wires	All	50	100 (5)	150	mA
ON Resistance (Excluding wire resistance)	VMot to U, V or W. Ground to U, V or W	SDC32xx		3.3		mOhm
Max Current for 30s	Motor current	SDC32xx			30	Amps
Continuous Max Current per channel	Motor current	SDC32xx			20 (6)	Amps
Current Limit range	Motor current	SDC32xx	10	30	30	Amps

TABLE 5.

Parameter	Measure point	Model	Min	Typ	Max	Units
Stall Detection Amps range	Motor current	SDC32xx	10	30 (7)	30	Amps
Stall Detection timeout range	Motor current	All	1	500 (8)	65000	msec
Short Circuit Detection threshold (9)	Between Motor wires or Between Motor wires and ground or Between Motor wires and Vmot	SDC32xx			78 (10)	Amps
Motor Acceleration/Deceleration range	Motor Output	All	100	500 (11)	65000	msec
Power cable thickness	Power input and output	All		12		AWG

Note 1: Negative voltage will cause a large surge current. Protection fuse needed if battery polarity inversion is possible  
 Note 2: Can be even higher because of regeneration voltage. Never inject a DC voltage from a battery or other fixed source  
 Note 3: Minimum voltage must be present on VBat or Power Control wire  
 Note 4: Factory default value. Adjustable in 0.1V increments  
 Note 5: Current consumption is lower when higher voltage is applied to the controller's VBat or PwrCtrl wires  
 Note 6: Estimate. Limited by case temperature. Current may be higher with better cooling  
 Note 7: Factory default value. Adjustable in 0.1A increments  
 Note 8: Factory default value. Time in ms that Stall current must be exceeded for detection  
 Note 9: Controller will stop until idle command given in case of short circuit detection  
 Note 10: Approximate value  
 Note 11: Factory default value. Time in ms for power to go from 0 to 100%

## Command, I/O and Sensor Signals Specifications

TABLE 6.

Parameter	Measure point	Min	Typ	Max	Units
Main 5V Output Voltage	Ground to 5V pins on	4.6	4.75	4.9	Volts
5V Output Current	5V pins on Molex and DSub25			150 (1)	mA
Digital Output Voltage	Ground to Output pins			30 (2)	Volts
Output On resistance	Output pin to ground		0.25	0.5	Ohm
Output Short circuit threshold	Output pin	1.7		3.5	Amps
Digital Output Current	Output pins, sink current			1.5(2)	Amps
Input Impedances (except DIN7-8)	AIN/DIN Input to Ground		53		kOhm
Digital Input 0 Level	Ground to Input pins	-1		1	Volts
Digital Input 1 Level	Ground to Input pins	3		30	Volts
Analog Input Range	Ground to Input pins	0		5.1	Volts
Analog Input Precision	Ground to Input pins		0.5		%
Analog Input Resolution	Ground to Input pins		1		mV

TABLE 6.

Parameter	Measure point	Min	Typ	Max	Units
Pulse durations	Pulse inputs	20000		10	us
Pulse repeat rate	Pulse inputs	50		250	Hz
Pulse Capture Resolution	Pulse inputs		1		us
Minimum Pulse on or Pulse off duration	Pulse inputs	25			us
Frequency Capture	Pulse inputs	100		2000	Hz
Encoder Frequency				200	kHz

Note 1: Sum of all 5VOut outputs  
 Note 2: Outputs are Open Drain. They pull to ground when on and float when off. Load must be connected between output and positive voltage

## Operating & Timing Specifications

TABLE 7.

Parameter	Measure Point	Min	Typ	Max	Units
Command Latency	Command to output change	0	0.5	1	ms
Maximum PWM duty cycle	Motor Output			96.9	%
Closed Loop update rate	Internal		1000		Hz
RS232 baud rate	Rx & Tx pins		115200 (1)		Bits/s
RS232 Watchdog timeout	Rx pin	1 (2)		65000	ms

Note 1: 115200, 8-bit, no parity, 1 stop bit, no flow control  
 Note 2: May be disabled with value 0

## Scripting

TABLE 8.

Parameter	Measure Point	Min	Typ	Max	Units
Scripting Flash Memory	Internal		32000		Bytes
Integer Variables	Internal		4096		Words (1)
Boolean Variables	Internal		8192		Symbols
Execution Speed (2)	Internal	30,000		70,000	Lines/s

Note 1: 32-bit words  
 Note 2: Execution Speed was calculated based on low communication load with the controller. In high communication workload, minimum time might be reduced drastically.

## Thermal Specifications

TABLE 9.

Parameter	Measure Point	Min	Typ	Max	Units
Case Temperature	Case	-40		85 (1)	°C
Thermal Protection range	Case	80		90 (2)	°C
Power Dissipation	Case			10	Watts
Thermal resistance	Power MOSFETs to plate			0.6	°C/W
Humidity	Case			95	%
Ambient temperature	Ambient			55	°C
Pollution Degree	-	PD 2			
Fast fuse to install(3)(4)	SDC32xx	20	2 x 20		Amps
Overload protection	-	Check Note 5			
Note 1: Thermal protection will protect the controller power Note 2: Max allowed power out starts lowering at minimum of range, down to 0 at max of range Note 3: There are two power terminal inputs. Fuse should be installed in both of them for safety. Note 4: For operating only one channel install 20A fuse and for operating more channels 2 x 20A fuse should be installed. Power source must be capable to blow the fuse instantly in case of short circuit Note 5: Current limiting mechanism available through firmware. External overload motor protection can be used if required (provided by user)					

## STO Specifications

TABLE 10.

Parameter	Measure Point	Min	Typ	Max	Units
STO Input High Level	Ground to STO input pin	6		30	Volts
STO Input Low Level	Ground to STO input pin	0		1	Volts
STO Response Time	Input to output change			5	msec
STO Operating temperature		-20		55	°C
STO Storage temperature		-20		70	°C
Humidity		5		95	%
IP degree				IP40	
Operating Altitude				2000	m
Cable Length				2	m
EMC Immunity	According to IEC 61800-3 and IEC 61800-5-2 Annex E				
CE Declaration	Available at <a href="http://www.roboteq.com">www.roboteq.com</a>				

## Mechanical Specifications

TABLE 11.

Parameter	Measure Point	Min	Typ	Max	Units
Weight	Case		215 (0.47)		g (lbs)
Power Connectors Wiring	Screw terminals	22		12	AWG
Torque	D-sub standard connector		0.4 (3.54)		Nm (in-lbs)
Torque	Terminal block		0.8 (7.10)		Nm (in-lbs)
Torque	Mounting screws (4/M2.5)		0.36 (3.2)		Nm (in-lbs)

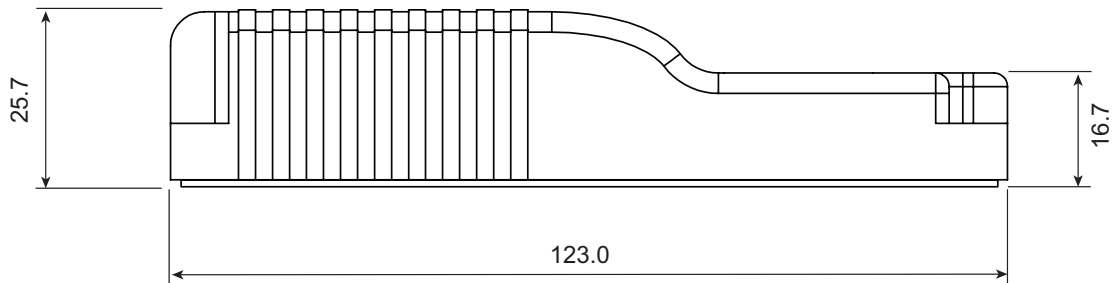

FIGURE 12. SDC3260 Side View and Dimensions

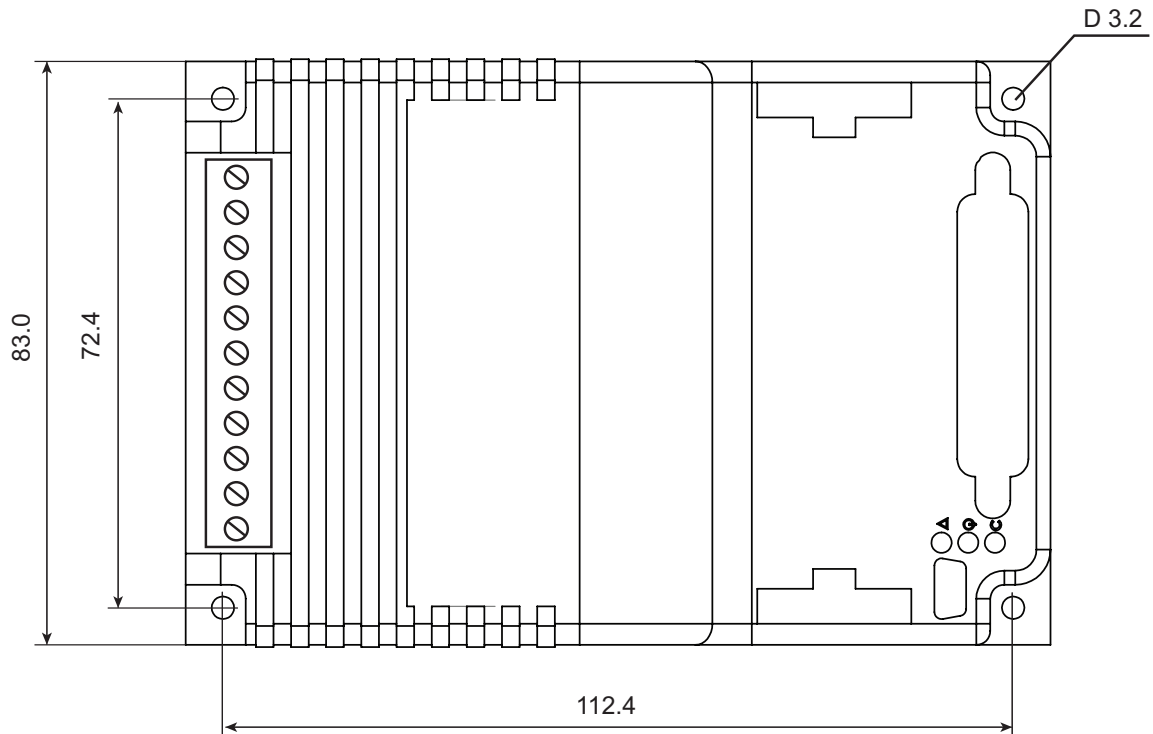

FIGURE 13. SDC3260 Top View and Dimensions