

Enquiry N°:

Created by: DB / Approved by: JD

SERVO MOTOR – 060LDB305LGCTG100620-SGV1

SMA507
060LDB305LGCTG100620-SGV1
AGV Solution Motor + Gearbox + Wheel
Up to 400kg Payload



Definition

Type	Unimotor HD	
Frame Size (mm)	060	
Voltage	L	Ultra-Low Voltage
Magnet type	D	High Dynamic
Frame Length	B	
Speed (min ⁻¹)	30	3000 @48Vdc – 1500@ 24Vdc
Brake	5	Braked
Connection type	L	Flying lead power (0.5 m) with RoboteQ drive connection
Output shaft	G	Integrated Gearbox Shaft
Feedback device code	CT	4096ppr incremental encoder (CTD/Motion)
Inertia & thermistor	G	Standard inertia + No thermistor
PCD (Gbox)	100	100 (Gear box)
Shaft Diameter	620	G BOX output
Fan Box	-	
Insulation class	F	
UL Motor / UL Stator	UL Stator	

Nominal characteristics

Motor Ambient Temperature (°C)	40	Drive Fsw (kHz)	12
Motor Stall Torque (Nm)	1.28	Stall Current (A)	9.79
Rated Torque (Nm)	1.28	Nominal Current (A)	9.79
Motor Peak Torque (Nm)	4.5	PeaK Current (A)	29.37
Rated Power (kW)	0.40	Kt (Nm/A)	0.13
Winding Thermal Time Constant (s)	55	Ke (V/kmin-1)	8.30
Number of Poles	10	R (ph-ph) (Ohm)	0.23
Maximum Cogging (Nm)	0.02	L (ph-ph) (mH)	0.7
Inertia Motor + Gearbox (kg.cm ²)	~0.5	Weight Motor + Gearbox (kg)	~6.0
Ingress Protection Level (IP)	IP54		
Brake	Spring-applied	Static Torque (Nm)	1.524
Release Time (ms)	50	Backlash (°)	
Brake Supply Voltage (V)	24.0	Brake Coil Power (W)	7.2

Torque / speed graph

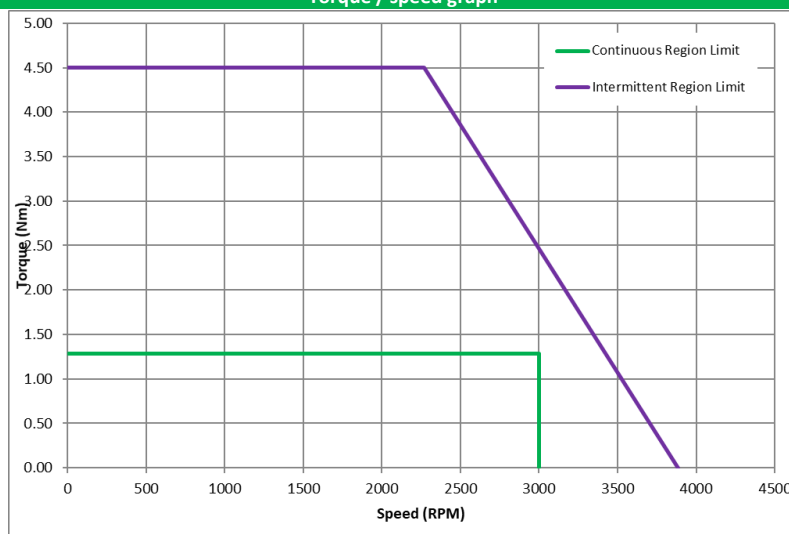

Enquiry N°:

Created by: DB / Approved by: JD

SERVO MOTOR – 060LDB305LGCTG100620-SGV1

Motors (° & mm)

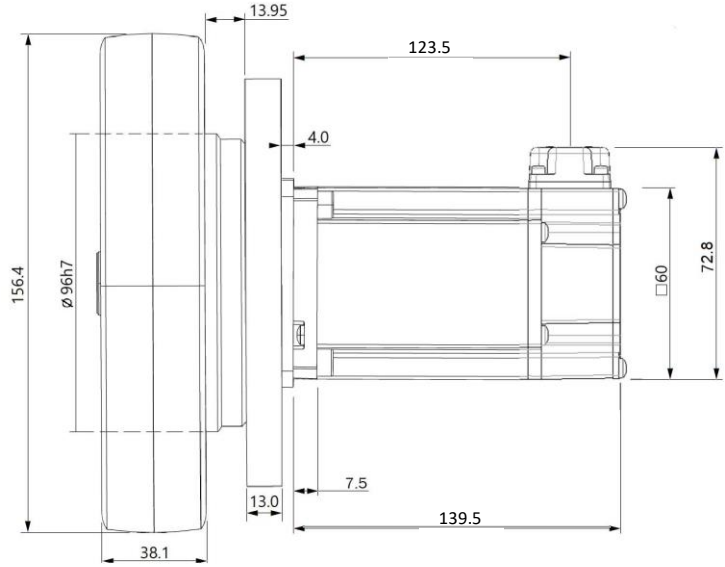
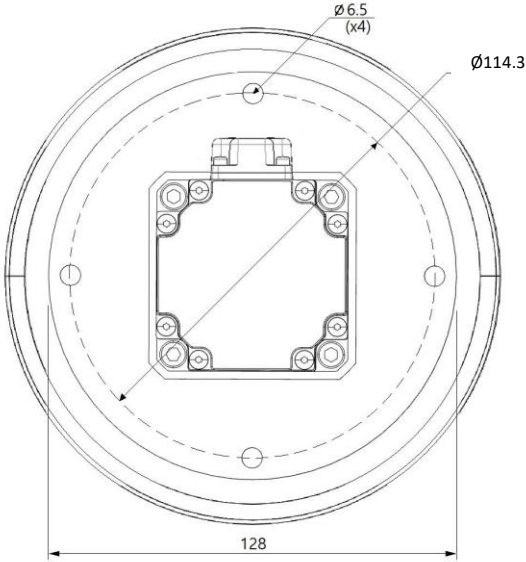

Motor electrical interface Connectors option:

Feedback device code: CT – 4096ppr incremental encoder				Connection type: L – Power & Signal flying leads Roboteq connection	
1	Power	7	CH A	U	Black 1
2	S1	8	-	V	Black 2
3	S2	9	CH B	W	Black 3
4	S3	10		Earth	Green/Yellow
5	GND	11		Black	Brake
6		12		White	Brake
Signal Cable: 500mm (from gland to customer end) 12-Way MOLEX Connector, Molex part number 43025-1200, loom with PVC jacket.				Power Cable: 500mm (from gland to customer end) Cable 4 + 2 core orange PUR screened 4 x 1.0mm ² wires 300/500V 2x 0.5mm ² wires Cable O/D 9.8mm With red ferrules for power & earth, white ferrules for brake	

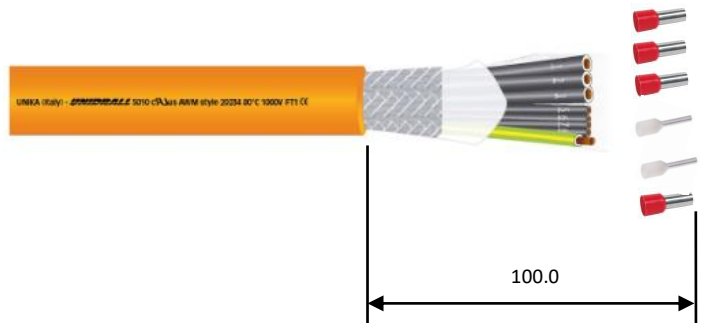
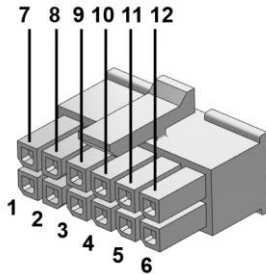

Enquiry N°:

Created by: DB / Approved by: JD

SERVO MOTOR – 060LDB305LGCTG100620-SGV1

Gear Box characteristics

Ratio	9	Backlash (arc/min)	≤7
Stages	1	Radial Load (Fr, N) @ Fa=0, Input Speed Nom	3500
Inertia (kg.cm ²)	~0.2	Radial Load MAX (Fr, N)	7250
Weight (kg)	2.7	Axial Load (Fa, N) @ Fr=0, Input Speed Nom	2200
Efficiency	95%		

