



SCHLUMPF
A DOUBLE E COMPANY



Custom Roll, Shaft & Material Handling **SOLUTIONS**

Hoist Based Roll Handling

Lift & Turn Handling

Lift and Turn a roll or material with the greatest of ease. They are designed for manual or powered turning of rolls between horizontal and vertical.

- Effortless, easy to use turning!
- Lift and Rotate rolls and reels between horizontal and vertical by the core
- Unload rolls and reels onto machine spindles or carts
- Loading or unloading pallets
- Universal Mandrel Holder for easy change between core sizes

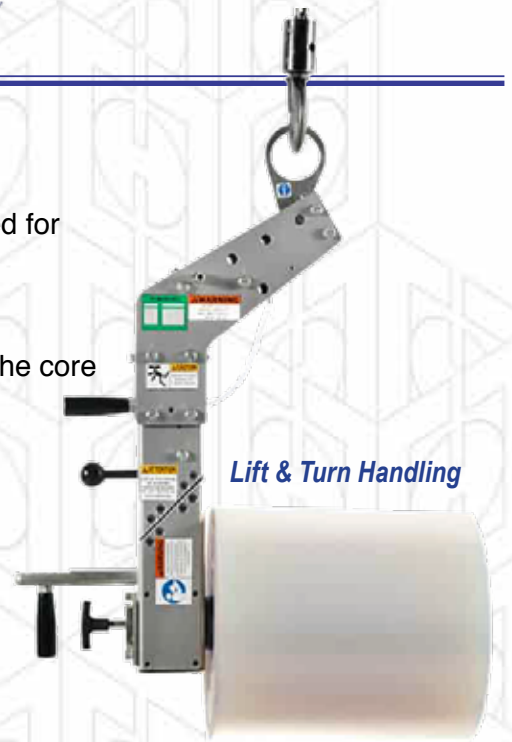

Horizontal Roll Lift

Schlumpf's Horizontal Roll Lifters are used to transport rolls in a horizontal position. The unit is supported by a hoist and allows operators to load or unload the rolls onto a machine spindle and to/from a roll cart or table.

- Below-the-hook lifting devices attach to standard hoist hooks
- Lift roll by the core or by supporting the outside diameter
- Manual, powered and automatic load leveling systems available
- Multiple tooling options available, including cradle and probe.
- Pneumatic gripper retract and pusher systems available

Vertical Roll Lift

Lift and transport rolls by their core in a vertical position. A hoist is used to maneuver the rolls from a pallet, work table or to a cart.

- Below-the-hook lifting devices attach to standard hoist hooks
- Safely lifts rolls by the core
- Fail safe gripper design securely holds rolls
- Changing between mandrel sizes is quick and easy



Portable Roll Handling

Light Duty Roll Handlers

Holding the rolls inside the core without contacting the valuable material reduces the risk of both material damage and operator injury, saving your company money and valuable resources.

- Lightweight aluminum frame
- Customizable height
- Compact Euro or Adjustable Straddle base
- Powered Raise and Lower
- Ergonomic and efficient
- Several manual tooling options including: flat platform, roll cradle, probe, roll turner, and swivel top



Light Duty Roll Handlers

Heavy Duty Roll Handlers

Powered Roll Handling Trucks are used to lift, transport load and unload rolls and products. Tooling options, custom and standard, offer users a variety of productivity enhancing benefits.

- Adjustable Straddle, Euro style or Counter Balanced bases
- Custom tooling options
- Ergonomic Design
- Capacities up to 1500lbs (680kg)



Heavy Duty Roll Handlers

V-Cradle Roll Handlers

Our powered lift trucks with cradle tooling make moving large rolls around easy! With powered drive and lift mechanisms they can achieve a multitude of jobs.

- 2 Speed operation
- Custom configurations available
- Able to load unwind/rewind shafts
- Hydraulic lip to mate with pallet
- Contoured forks available
- Custom capacities available!



V-Cradle Roll Handlers

Shaft Handling

Light Duty Shaft Handlers

Schlumpf's ESH portable electric shaft handling machines are versatile tools for many shaft handling applications. Designed for portability, ease of use and flexibility, these 24 volt battery powered shaft handling machines make lifting, inserting, extracting and transporting heavy shafts, reel spools and tissue core plugs safe and easy.



Light Duty Shaft Handlers

- Easy to push and maneuver
- Rugged
- Low maintenance
- Powerful electric clamp
- Custom column heights

Heavy Duty Shaft Handlers

Schlumpf offers heavy duty shaft handlers with the ability to lift, turn and rotate air shafts and shafted products. Custom tooling is available as an option to ensure the handler is equipped with the capabilities to do exactly what you need it to do and improve production floor efficiency and safety.

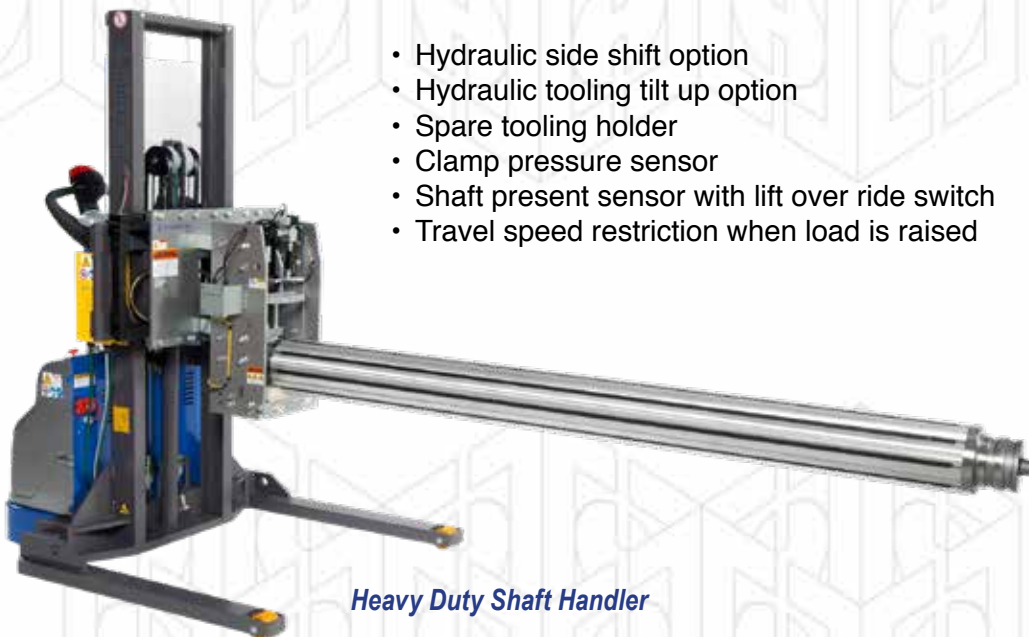

Heavy Duty Shaft Handler

- Hydraulic side shift option
- Hydraulic tooling tilt up option
- Spare tooling holder
- Clamp pressure sensor
- Shaft present sensor with lift over ride switch
- Travel speed restriction when load is raised

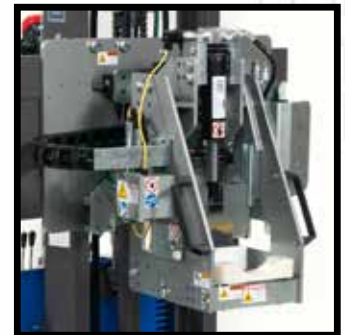

Chucks

PCS Heavy Duty Pneumatic Core Chucks

The modular PCS expanding core chuck system offers unparalleled precision and versatility in high speed or high tension shaftless unwinding and rewinding applications where little or no variation in web tension or web position can be tolerated.

*PCS Heavy Duty,
Pneumatic Core Chucks*



PCS Adapter System

Offering limitless possibilities, Schlumpf adapter collars simply slide over the nose of the base chuck. As such, roll core sizes can be changed in seconds with little effort. We offer hundreds of core chuck designs and adapter configurations to suit both new and retrofit applications.



Adapter Collar on Pneumatic Chuck



Adapter Collars

Portable Dollies & Tables

Portable Roll Dollies



Portable Roll Dollies

With a maximum lifting weight of 1000 lbs., Schlumpf's Portable Roll Dollies offer an inexpensive way to transport rolled materials and other equipment throughout your plant, keeping valuable material off the floor and clean. With a rugged steel construction and powder coat finish our Portable Roll Dollies are tough and handle the heaviest loads with ease.

Discovery PB

A roll pallet truck with shaped forks, allowing for safe and efficient handling of rolls, reels, and coils. The length, width, and shape of the forks are fully customizable.

- Custom widths available
- Highly maneuverable
- Designed for super-high capacities



TE Stairway Lift Table

TE Stationary Lift Table

TE electric lifting tables are stationary lifting tables that operate on three-phase 380/220 V. It is an ideal solution for a large number of applications such as loading/unloading goods to/from motor vehicles, a connection between different work cells, servicing machines and many other industrial and non-industrial uses.

Roll Upenders

Schlumpf designs and manufactures roll upenders tailored to your application to ensure they produce the results and production rates that provide you with a competitive advantage. The quality, performance and durability is unparalleled in the industry. Schlumpf's hydraulic roll upenders are used to upend rolls, reels and virtually any heavy loads and turn them 90 degrees.



Upenders

Stacker Trucks & Lifts

Power Movers & Tow Trucks

TPT and TPT UB are Armani line of industrial power movers and electric tow carts and offer options such as walk behind or operator-ride-on capacities. They are battery powered which eliminates emissions, improves air quality and enhances operator safety.

Powered Movers & Tow Trucks



Drum Handlers



Drum Handlers

Lifting, transporting and emptying heavy drums is difficult, time consuming and potentially unsafe. With heightened awareness of efficiency and skyrocketing medical costs, having a safe, fast and easy way to handle drums is a key to both productivity & profitability.

Semi-Electric Stacker

The Armani Semi-electric stackers combine manual traction and electric elevation. This is the ideal solution for moving medium-light loads.

Semi-Electric Stacker



Electric Stacker



Electric Stacker

The Armani electric stacker models offer a variety of maneuvering and handling capabilities. The MOSFET control technology makes control reaction time extremely fast which makes controlling the unit safe and more accurate. And, the regenerative braking system feeds energy generated during braking/stopping back into charging the battery.

Electric Pallet Trucks

The Armani electric pallet trucks offer a variety of maneuvering and handling capabilities. The units can be equipped with a variety of options to handle products and pallets. These units have been engineered with durability, ease of use and safety in mind.

Armani Discovery Electric Pallet Truck



Manual All Terrain Pallet Jacks



Multi Terrain Pallet Jacks & Stackers

Conhersa's specialized all-terrain pallet trucks and stackers are the perfect solution. Available in both manual and electric versions, these sturdy machines make it easy to move heavy loads through harsh conditions.

Customized Handling

Custom Lift & Turn Devices

Schlumpf manipulators are designed to maximize operator efficiency and ergonomics in handling awkward or heavy materials and products. The units reduce and or eliminate stressful repetitive motions by virtually eliminating the effects of gravity to create a “zero-gravity, five-axis” work cell.

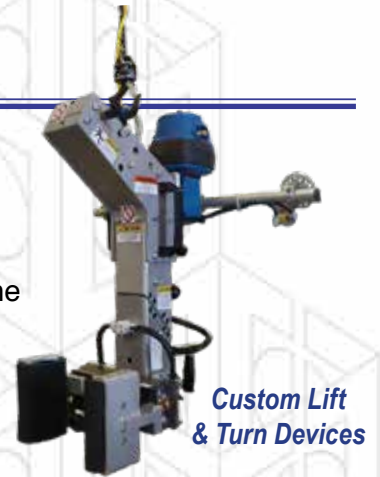

Custom Lift & Turn Devices



Custom Lift Tables

Custom Lift Tables

These custom lift tables were developed to create a safe means of moving a variety of products around a shop floor. They enhance the speed at which operators can move around the production floor without risking their own safety or their fellow operators’.

Accessories

Pallet Carousel

Pallet Riser Carousels are useful in situations where a pallet full of rolls is not accessible from all sides. The 360° rotation feature allows the operator to approach from one side of the pallet to remove all of the rolls



Pallet Carousel



Expanding Mandrels

Universal Mandrels are fail-safe. Grippers expand automatically by spring force. Simply insert the mandrel into the core and lift the roll.

Expanding Mandrel

Parts and Service

To help keep your equipment in top-shape and avoid expensive down-time, keep your Schlumpf and Armani products running with high-wear parts and accessories. Contact us for recommended spare parts kits, preventative maintenance schedules, manuals, diagrams and more.